



KIESELMANN

FLUID PROCESS GROUP

Translation of the original

Operating Instructions

Control Head IO-Link

Type 5634

GEN 3



KIESELMANN GmbH

Paul-Kieselmann-Str. 4-10
D - 75438 Knittlingen

 +49(0) 7043 371-0 •  +49(0) 7043 371-125
www.kieselmann.de • info@kieselmann.de

Copyright: © KIESELMANN FLUID PROCESS GROUP

Manufacturer: AquaDuna GmbH & Co.KG

Table of Contents

1	General informations	4
1.1	Informations for your safety	4
1.2	Marking of security instructions	4
1.3	General designated use	4
1.4	Personnel	4
1.5	Modifications, spare parts, accessories	5
1.6	General instructions	5
2	Safety instructions	6
2.1	Intended use	6
2.2	General notes	6
2.3	General safety instructions	6
3	Delivery, transport and storage	8
3.1	Delivery	8
3.2	Transport	8
3.3	Storage	8
4	Disposal	9
5	Specification	10
6	Function and operation	11
6.1	Function	11
6.2	Control of the actuator	11
6.3	Positioning	11
6.4	Pulse cleaning technology	11
6.5	ES Function	12
6.6	Application	13
6.7	LED signalling	14
6.8	Electrical connections	15
6.9	Setting Pulse generator for Lift valves	16
7	Assembly	17
8	Commissioning	18
8.1	Commissioning	18
8.2	Teaching	18
8.3	Integration into a plant	18
9	Malfunctions	19
9.1	Emergency stop	19
10	Disassembly	20
11	Technical data	21
11.1	Dimensions	21
12	Wearing parts	22
13	Appendix	23
13.1	Annex 1	23
13.1.1	IO-Link Process Data	23
13.1.2	IO-Link Parameters	24
13.1.3	IO-Link commands	26
13.1.4	IO-Link diagnostic messages	26
13.2	Annex 2	27
13.2.1	Program setting [S]	27

1 General informations

1.1 Informations for your safety

We are pleased that you have decided for a high-class KIESELMANN product. With correct application and adequate maintenance, our products provide long time and reliable operation.





Before installation and initiation, please carefully read this instruction manual and the security advices contained in it. This guarantees reliable and safe operation of this product and your plant respectively. Please note that an incorrect application of the process components may lead to great material damages and personal injury.

In case of damages caused by non observance of this instruction manual, incorrect initiation, handling or external interference, guarantee and warranty will lapse!

Our products are produced, mounted and tested with high diligence. However, if there is still a reason for complaint, we will naturally try to give you entire satisfaction within the scope of our warranty. We will be at your disposal also after expiration of the warranty. In addition, you will also find all necessary instructions and spare part data for maintenance in this instruction manual. If you don't want to carry out the maintenance by yourself, our KIESELMANN - service team will naturally be at your disposal.

1.2 Marking of security instructions

Hints are available in the chapter "safety instructions" or directly before the respective operation instruction. The hints are highlighted with a danger symbol and a signal word. Texts beside these symbols have to be read and adhered to by all means. Please continue with the text and with the handling at the valve only afterwards.

Symbol	Signal word	Meaning
	DANGER	Imminent danger which will result severe personal injury or death.
	WARNING	Imminent danger which may result severe personal injury or death.
	CAUTION	Dangerous situation which may cause slight personal injury or material damages.
	NOTICE	An harmful situation which may result in damages of the product itself or of adjacent vicinity.
	INFORMATION	Marks application hints and other information which is particularly useful.

1.3 General designated use

The fitting is designed exclusively for the purposes described below. Using the fitting for purposes other than those mentioned is considered contrary to its designated use. KIESELMANN cannot be held liable for any damage resulting from such use. The risk of such misuse lies entirely with the user. The prerequisite for the reliable and safe operation of the fitting is proper transportation and storage as well as competent installation and assembly. Operating the fitting within the limits of its designated use also involves observing the operating, inspection and maintenance instructions.

1.4 Personnel

Personnel entrusted with the operation and maintenance of the tank safety system must have the suitable qualification to carry out their tasks. They must be informed about possible dangers and must understand and observe the safety instructions given in the relevant manual. Only allow qualified personnel to make electrical connections.

1.5 Modifications, spare parts, accessories

Unauthorized modifications, additions or conversions which affect the safety of the fitting are not permitted. Safety devices must not be bypassed, removed or made inactive. Only use original spare parts and accessories recommended by the manufacturer.

1.6 General instructions

The user is obliged to operate the fitting only when it is in good working order. In addition to the instructions given in the operating manual, please observe the relevant accident prevention regulations, generally accepted safety regulations, regulations effective in the country of installation, working and safety instructions effective in the user's plant.

2 Safety instructions

2.1 Intended use

These control heads Type 5633 are designed to be used only on FLUID PROZESS GROUP actuators. They may only be used in the areas intended for this purpose. Any application other than intended is forbidden. Application must be made only by qualified and instructed persons. Modifications are not covered by the manufacturer.

2.2 General notes



NOTICE - observe the operating instructions

These operating instructions are an integral part of the product and must be available to the user at all times. Every safety instruction is to be made sufficiently known and to be observed. If the unit is passed on, the operating instructions must be passed on as well.



NOTICE

All data are in line with the current state of development. Subject to change as a result of technical progress.

2.3 General safety instructions



NOTICE

Safety requirements

The operator of the control head is obliged to train the operating personnel as well as the personnel authorized to carry out the maintenance. Everybody who works with controlling pneumatic actuators, must be informed about the dangers that these devices may present.

Persons being not listed as operating and maintenance personnel, are not allowed to stay in the operating range of the devices. The operator must see to the necessary measures to be taken.

As a general rule, the devices must be maintained solely by qualified personnel. Only original spare parts must be used. If OEM parts are used, warranty will be lost.

Every assembly work carried out at the control head is to be done in stressfree condition.



NOTICE

Loss of warranty if non-original components are used

Damages which result from the use of OEM parts, won't be accepted by the manufacturer.

The control heads are operated with 6 - 8 bar compressed air. Due to the design, stagnation pressure may arise in the cover of the control head in case of leakage. Notification is hereby made that only original spare parts must be used for repair / maintenance.



⚠ WARNING

No ATEX approval

The control head IO-Link is not approved for operation in the ATEX area.



⚠ WARNING

Destruction of the control head cover

If the cap is not completely screwed down, the cover may be destroyed through the stroke movement of the piston rod.

- If the pulse generator which is in the control head, is removed or put in, make sure that the closing cap is screwed down until the metallic stop.

**⚠ CAUTION****Danger due unintended use**

The control head must be operated only in the ambiance intended for it.

**⚠ CAUTION****Damage to the control head cover**

The control head cover is fitted with bayonet catch. Make sure that no tools are used to loosen the cover and that the respective sense of rotation to open and/or close is observed.

**⚠ CAUTION****Risk of injury due to pressure in the control head**

When handling the control head, take into consideration that the hood may be under pressure. When removing it, make sure that the hood is held fast.

**⚠ CAUTION****Damage due to incorrect operation**

Only authorized persons are allowed to stay in the operational area of the control head.

3 Delivery, transport and storage

3.1 Delivery

Our products are very carefully produced, mounted and tested. Should there be any reason for complaint, we will naturally give you entire satisfaction within the scope of our warranty. We will be pleased to help you after expiry of warranty, too.



NOTICE

When receiving a delivery, always check the packing list against the delivery scope. After having noticed that delivery is complete, the goods must be checked for damage.

If there are damages, it is essential to note them down on the shipping documents. In case of damage, the forwarder must countersign the documents.

- | | |
|----------------|---|
| Delivery scope | <ul style="list-style-type: none"> • Control head • Quick guide • Instructions for use |
|----------------|---|



INFORMATION

You can learn the options from the shipping documents.

3.2 Transport

If parts are returned, either keep the outer package or use a packaging where the devices are not damaged.

3.3 Storage



NOTICE

Damage to the product due to improper storage!

Observe storage instructions
avoid a prolonged storage



INFORMATION

Recommendation for longer storage

We recommend regularly checking the product and the prevailing storage conditions during long storage times.

- Don't store any objects on the products.
- Protect the products for wetness, dust and dirt.
- The product should be stored in a dry and well ventilated room at a constant temperature (optimal indoor temperature: 25 C ±5 ; indoor humidity data 60% ±5%).
- Protect seals, bearings and plastic parts for UV light and ozone.

4 Disposal

If the control head is put out of operation, the plastic parts are to be recycled. The electronic sub-assembly is recycled correspondingly for the recovery of raw materials. You can dispose of these materials over the ways intended.



NOTICE

Make sure that there are not contaminations with materials from operation anymore. If so, the corresponding material for rinsing of the parts to be disposed, must be used.

5 Specification

The control head consists of a body with a bayonet lock onto which a plastic or stainless steel cover is fitted.

The electronic system is integrated in this body. Which allows to control and to acquire the positions of the valve. The valve actuator is controlled via the pilot valves.

The electrical connections are made via an M12 connector in the bottom part.

The control head is connected to the compressed air supply and the valve actuator via quick-release couplings.

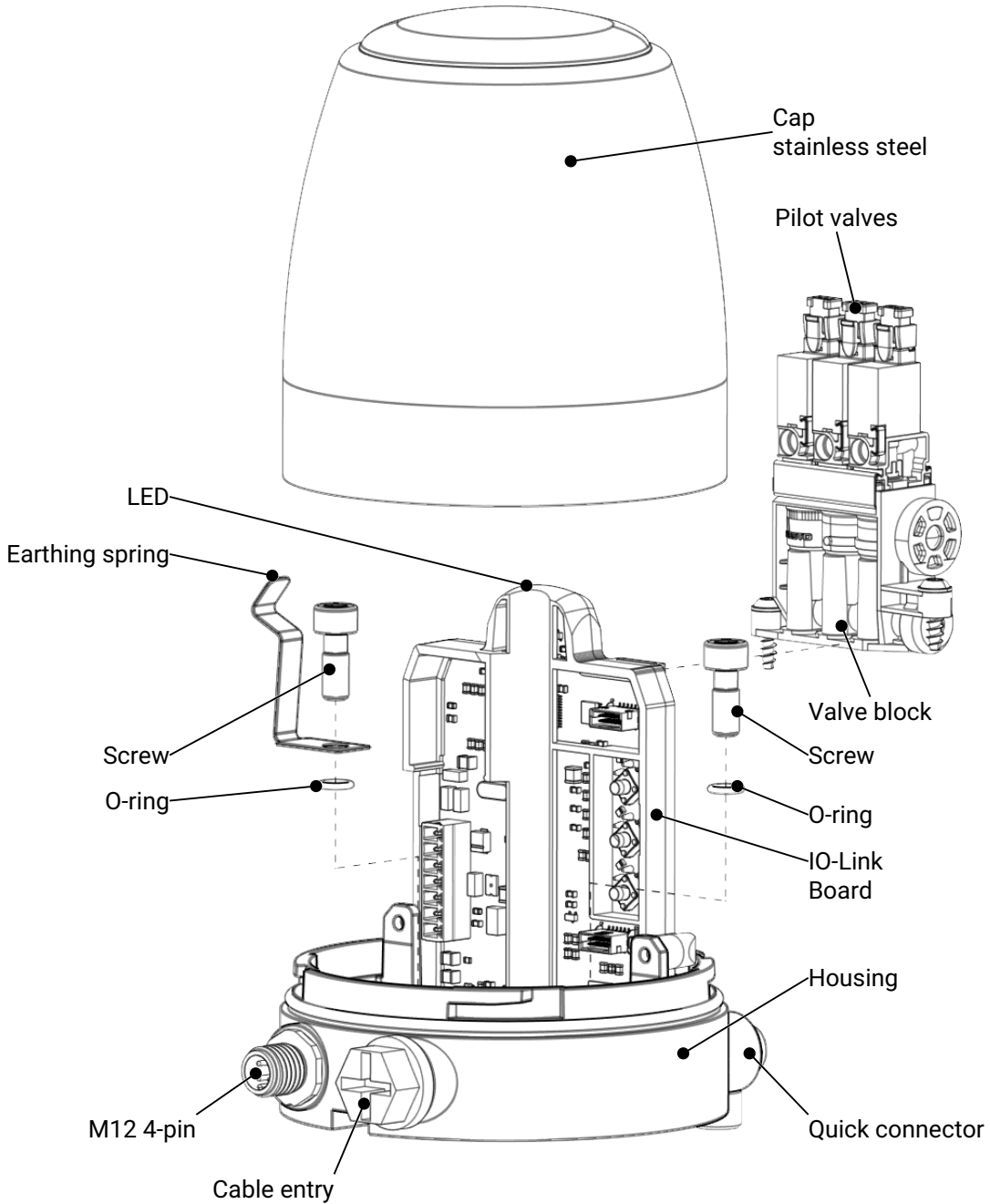

6 Function and operation

6.1 Function

The control head can be combined with the KIESELMANN valves. It is put on the valve drive and then screwed down.

The touchless magnetic sensor technology allows the application in different valve types. The positions of the valves are acquired over the electronics of the control head and forwarded to a higher-level control. The forwarding of the signals is made via a wiring provided for it.

The electronic system signalizes the valve conditions at the control head. The actuator is controlled over the integrated pilot valves. The supply of air is made either directly over the control head or over an external hose coupling.

Operation is allowed only in the intended environment.

6.2 Control of the actuator

The control of the actuator can be made over the installed or external pilot valves. External pilot valves are placed in the switchboard plants of the higher-level control. Internal pilot valves can be triggered over the hand emergency actuation.

6.3 Positioning

The position of the actuator is determined over a magnet carrier (pulse generator). This carrier is located in the axle of the valve.

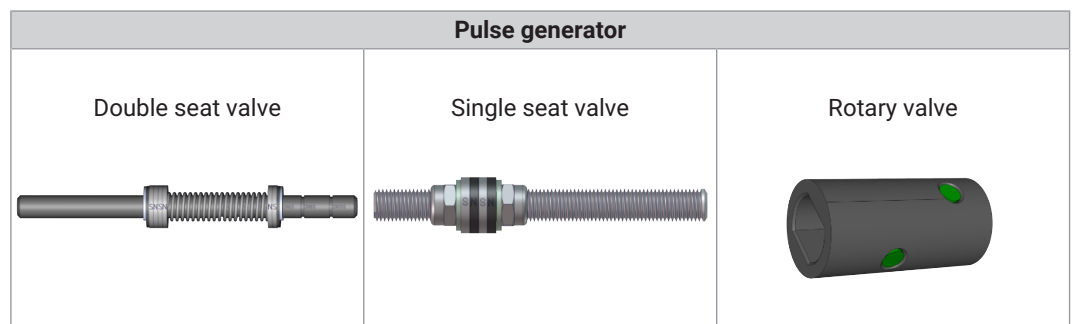

6.4 Pulse cleaning technology

When the KIESELMANN 'pulse' mode is activated, the valve and the valve seat are flushed extremely efficiently and in a resource-saving manner. Thanks to the newly developed and high-resolution position detection of the control head, the flushing and cleaning process is carried out in the shortest possible time and with minimal use of media.



INFORMATION

Please refer to the Annex 3 of this operating manual for the input commands for using this function.

6.5 ES Function

ES (Emergency Stop)

The control head has an emergency stop function. This makes it possible to override the input signal in an emergency so that the valve actuator moves to the basic position.

When supplied as standard, the ES function is deactivated by two fitted insertion bridges in connector P1.

There are two options to activate the ES function of the control head:

Option 1

Remove the insertion bridge (ESV to ESV+ or ESV- to GND) and connect your preferred switch to the now free position of the plug using cabling. The switch must interrupt the connection when actuated so that the ES function is activated and the valve actuator moves to the basic position.

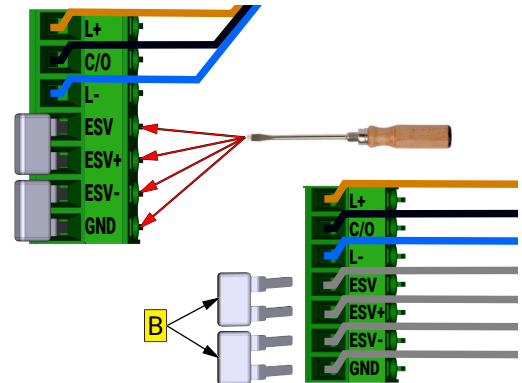

Option 2

Remove the insertion bridges (ESV to ESV+) and (ESV- to GND). Connect an external supply voltage of 24V to ESV+ and ESV-. The ESV and GND connections are not contacted in this circuit. As soon as the supply voltage is interrupted, the ES function is activated and the valve drive moves to the basic position.

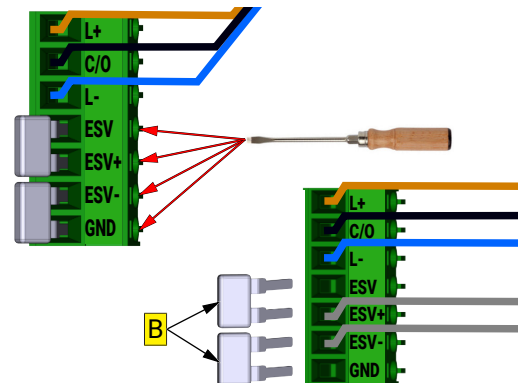

NOTICE

- When the ES function is activated, only spring-loaded valve actuators move to the basic position.
- When the emergency stop function is triggered, the signalling ('Error' - electrical error control head) flashes red / white (see also LED signalling ▶ 14]).
- If a switch is integrated, it must be a 'NORMALLY CLOSED' switch (normally closed contact / NC switch).

6.6 Application

These control heads are suitable for the application on KIESELMANN actuators for lift and turning valves.



NOTICE

- These control heads are designed to be used only on KIESELMANN actuators and must be used only in the intended ranges.
- They may only be used in the areas intended for this purpose.
- Any application other than intended is forbidden.
- Application must be made only by qualified and instructed persons.
- Modifications are not covered by the manufacturer.



WARNING

No ATEX approval

The control head IO-Link is not approved for operation in the ATEX area.

6.7 LED signalling

Signalling of the actuator position via LEDs on the circuit board.

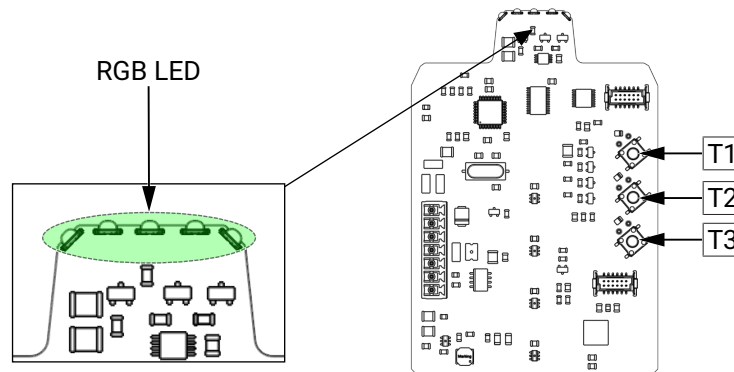

Lift and Rotary Valves		
Valve position	RGB LED colour	Signalling
open	green	throughout
close	red	throughout
during valve movement	red / green	flashing

Lift and rotary valves with cycle and 'pulse' function		
Valve position	RGB LED colour	Signalling
Cycle / "pulse" below	red	flashing
Cycle / "pulse" above	green	flashing

Teaching – Button T1		RGB LED colour	Signalling
Control head	not enabled	red / turquoise (cyan)	flashing
	during teaching	turquoise (cyan)	flashing
	Error during teaching process	red / turquoise (cyan)	flashing

Manual operation / manual switching of solenoid valves via push-button Tx		
Valve position	Valve position (red / green)	3s continuous - (3s flashing)
	Manual operation (red / white)	3s flashing

Error		
electrical error control head	red / white	flashing

6.8 Electrical connections

Position of the connectors

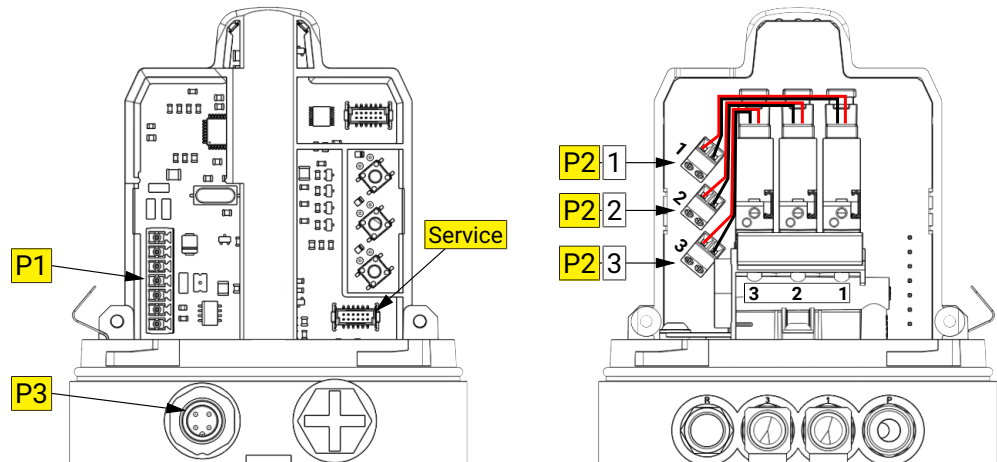

Connector 7 pin [P1]

Pin 1	L+	brown	
Pin 2	C/O	Data input black	
Pin 3	L-	blue	
Pin 4	ESV	-	
Pin 5	ESV+	-	
Pin 6	ESV-	-	
Pin 7	GND	-	

Connector 2 pin [P2]

Pin 1	red	
Pin 2	black	

Electrical connection external input M12 connector 4pin [P3]

Pin 1	L+ Bus signal	brown	
Pin 2	Not used	-	
Pin 3	L- Bus signal	blue	
Pin 4	C/O	Data input black	

6.9 Setting Pulse generator for Lift valves

Pulse generator double seat mixproof valve

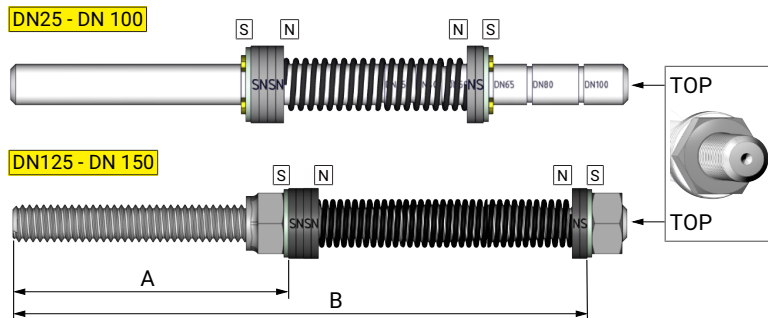

e.g.: 56xx, 564x, 565x, 567x, 568x, 569x, 5000

The setting for nominal sizes DN 25 to DN 100 is specified via the notches on the bolt and secured with a retaining ring.

DN	A	B	Pulse generator
DN 25 – DN 100	-	-	5620.DN.005-K000
DN 125 – DN 150	56.5 mm	122.5 mm	5620.150.005-K000

Pulse generator Single seat valves

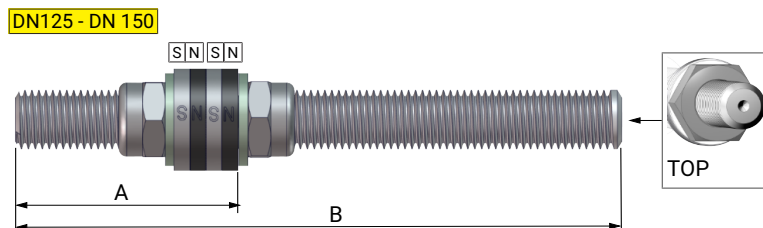

e.g.: KI-DS Valve series 55xx

DN	A	B	Pulse generator
DN 25 - DN 150	30 mm	90 mm	5500.150.005-K000

7 Assembly



⚠ WARNING

Before putting the control head into operation, always check that every part is fixed. In case the control heads are not correctly mounted, the operator himself will be liable.

The control head is mounted on the actuator of the lift or turning valve respectively. The hexagon socket screws M6 with the fitted O-ring are required for mounting. If control heads with stainless steel hood are used, a spring is to be fitted for earthing according to (see illustration below).

In case of actuators whose diameter is smaller than 100 mm, use a distance plate. For rotary actuators, an encoder extension is also required to extend the puls generator.



NOTICE

- When mounting the control head, make sure that the O-rings are correctly mounted in the body of the control head.
- Install the control head on a clean valve actuator.
- Control heads with a stainless steel cover must be installed with an earthing spring.
- The spring connects the stainless steel hood with the actuator body. The actuator itself must not be incorporated in an insulated way toward the potential EARTH.
- Always mind the equipotential bonding.

- Mount the control head on the actuator using Allen screws (M6x16) (2x) with O-rings (2x).
- Connect the electrical and pneumatic connections.
- Place the cover on the housing and turn clockwise (15°).

Earthing spring

Art. No.: 5630000103-340

Adapter plate

Art. No.: 5630600076-087

Dog

Art. No.: 5630600077-059

Pulse generator

Art. No.: 5631600010-000

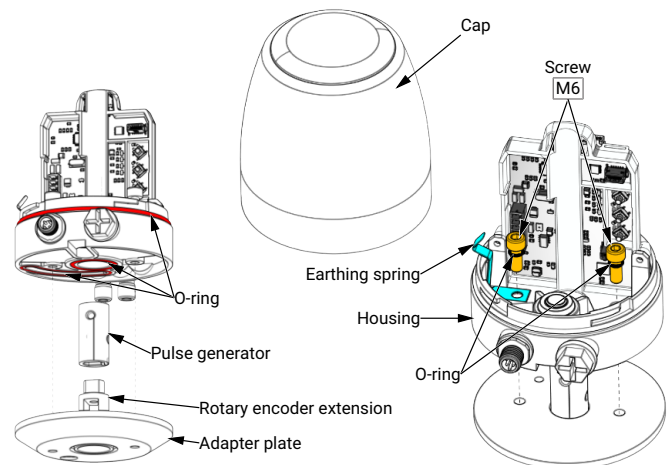

8 Commissioning

8.1 Commissioning

After all screws had been tightened and the air pipe as well as the electrical connection had been made, the control head is ready for commissioning.

The air supply must be made according to specification. Check if the filter body is set into the air entry of the control head and if all O-rings are correctly mounted.

Prior to commissioning, the air pipe toward the control head must be blown off. Metallic impurities, welding residues and other solid bodies may destroy the control head. Prior to commissioning, the air pipe toward the control head must be blown off. Metallic impurities, welding residues and other solid bodies may destroy the control head.

8.2 Teaching

Once the control head has been screwed and installed on the valve body, the control head must be taught in (teaching process). Please ensure that the control head is de-energised before carrying out the teaching process.

First, select the appropriate programme for your valve actuator – refer to the tables for programme positions Annex 2 [▶ 27]. The programme is set using programme setting (S). (The predefined parameters for each valve actuator are already stored on the control head circuit board).

- Press and hold the MV 1 button (T1) and insert the power supply plug (P1).
- Press and hold the MV 1 button (T1) for a further 3 seconds before releasing it. The teaching process now starts automatically.
- During the teaching process, the signalling light on the circuit board flashes turquoise (cyan).
- Once the teaching process has been successfully completed, the signalling changes to the specified standard value (red = valve closed / green = valve open).

QUICK GUIDE

- Disconnect the power supply connector (P1)
- Select programme setting (S)
- Press and hold the MV 1 button (T1)
- Insert power supply connector (P1)
- Press and hold the MV 1 button (T1) for a further 3 seconds and release

→ ... **Teaching process starts**

(see also LED signalling [▶ 14])

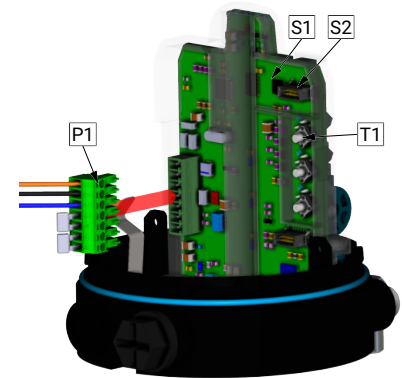

8.3 Integration into a plant

If the control head is integrated into an automatically working plant, make sure that the function of the control head can be monitored. Monitoring must be guaranteed by the plant design. An optical control has also to be carried out in certain time intervals. The function control must be documented in case of optical inspection. If faults or damages are determined during control, they must be immediately removed.



NOTICE

Make sure with remote-controlled valves that the mediums won't be mixed if the fittings are operated by hand emergency actuation.

In case of operation in automatically working plants the operators must familiarize with the cutoff or emergency stop of the plant respectively.

9 Malfunctions

9.1 Emergency stop



WARNING

In order to force an emergency stop of the control head, the operators of the plant must absolutely familiarize with the plant design.

- It is essential to train an emergency stop and to inform about the necessary elements regarding an emergency stop.
 - The training of the persons who were charged with the operation of the plant, must be documented.
 - Every damage to person and property which results from faulty operation or faulty application respectively, are borne by the plant operator.

10 Disassembly

Assembly Tools

1. Torx screwdriver T10, T20
2. Allen wrench Größe 5 mm
3. Screwdriver long blade size 3
4. Screwdriver size 2
5. Open-end spanner SW 13

Disassembly



NOTICE - observe the operating instructions

Dismounting of the control head is made when

- the control head or the valve shall be maintained
- parts of the control head shall be replaced

see *illustration* Assembly [▶ 17]

- Interrupted the air supply to the control head and disconnected the control head from the electric contact.
- Loosen the cover from the housing by turning it approx. 15° anti-clockwise and remove it (bayonet catch).
- Use a Torx screwdriver to remove the electronics or the sensors with the pilot valve block.
- **NOTICE! The pilot valve block is differently assembled. The block is built in without assembly in case of control by external valves.**

Dismantling body

- Loosen the pneumatic and electrical connections.
- Unscrew the allen screws (M6) (2x).
- Remove the housing upwards from the valve.

11 Technical data

IO-Link electronics

Supply voltage	24V DC
Supply voltage range	± 10%
Electrical nominal power	0,5 W (per solenoid valve)
<u>Current consumption</u>	
Maximum ¹ :	80 mA (24V DC)
Quiescent current ² :	32,5 mA
Ambient temperature	-10°C – +60°C
Protection class	IP 67 DIN EN 60529
with stainless steel hood	DIN EN 61140 I
with plastic hood	DIN EN 61140 I

1: Signalling with flashing RGB LEDs and three switched solenoid valves

2: Signalling RGB LEDs, no control of the solenoid valves

Requirements for the control air

DIN	ISO 8573-1:2010 [3:(≤5 µm):4:4]
Control air pressure	6 bar
Air volume	160 l / min / 6bar

11.1 Dimensions

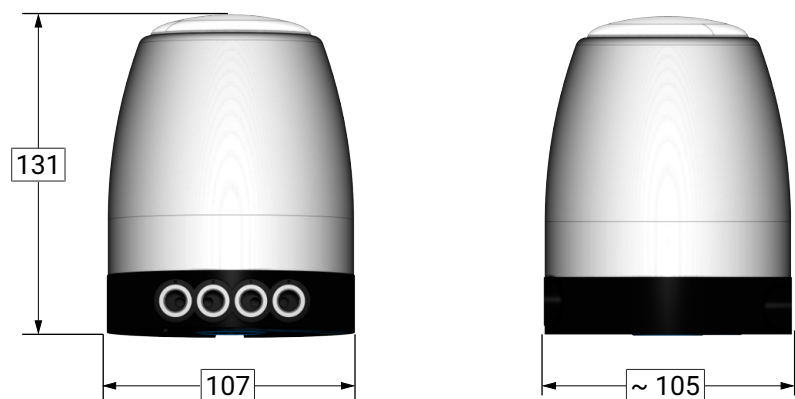

12 Wearing parts

Spare parts	Article number
Rotary encoder right	5630 600 010-000
Rotary encoder left	5630 600 010-001
Cap: stainless steel (LED with Logo)	5631 000 110-032
Cap: stainless steel (with Logo)	5631 000 118-021
Cap: Plastic (with Logo)	5631 000 002-094
Seal kit: O-ring	5631 000 006-000
Board IO-Link	5634 000 013-003
Screw set KI-TOP	5631 000 005-000
Spreader cap complete	5631 000 111-000
Valve block -321-Con	5633 003 013-000
Valve block -XX1-Con	5633 301 013-000
Valve block -X2X-Con	5633 601 013-000

13 Appendix

13.1 Annex 1

13.1.1 IO-Link Process Data

Input data from the master	
Byte 1	
Bit (low nibble)	Function
1	Close
2	Open
4	Lower seatlift
8	Upper seatlift
Hi Nibble	Must stay 0
Byte 2	
Bit 0	Identification signaling
Byte 3,4 not used, further use	

Output data to the master	
Byte 1	
Bit (low nibble)	Function
0	Unknown position / moving
1	Closed
2	Open
4	Lower seatlift
8	Upper seatlift
Hi Nibble	0
Byte 2	
Bit 0	Remote Rec. plugged
1	Remote locked
2	Teaching
3 - 7	Not used
Byte 3,4 not used, further use	

13.1.2 IO-Link Parameters

13.1.2.1 Parameter table

Index (dec)	Index (hex)	Type	Size	Parameter		Access	Value range	Default setting	Hardware
64	0x40	Uint8	8 Bit	Vtype	Valve type	rw	0..31	0	
73	0x49	Uint8	8 Bit	LED Mode	Brightness TopLed	rw	0..4	4	
75	0x4B	Uint8	8 Bit	Op Mode	Operation Mode <i>Bit0 : disable Sig. Moving</i>	rw		0	
76	0x4C	Uint8	5* 8 Bit	FP_Closed	Fingerprint closed	rw		0	Premium
77	0x4D	Uint8	5* 8 Bit	FP_Open	Fingerprint open	rw		0	Premium
78	0x4E	Uint8	5* 8 Bit	FP_LowerSeatlift	Fingerprint Lower Seatlift	rw		0	Premium
79	0x4F	Uint8	5* 8 Bit	FP_UpperSeatlift	Fingerprint Upper Seatlift	rw		0	Premium
80	0x50	Uint16	16 Bit	Angle Closed		rw	0..1023	0	Further use
81	0x51	Uint16	16 Bit	Angle Open		rw	0..1023	0	Further use
82	0x52	Uint8	8 Bit	PosTolerance Close	Tolerance closed	rw		0	Premium
83	0x53	Uint8	8 Bit	PosTolerance Open	Tolerance open	rw		0	Premium
84	0x54	Uint8	8 Bit	PosTolerance LowerSeatlift	Tolerance lower seat lift	rw		0	Premium
85	0x55	Uint8	8 Bit	PosTolerance UpperSeatlift	Tolerance upper seatlift	rw		0	Premium
65	0x41	Uint16	16 Bit	C_PwrOn	Counter power on	ro		0	
66	0x42	Uint16	16 Bit	C_Close	Counter close	ro		0	
67	0x43	Uint16	16 Bit	C_Open	Counter open	ro		0	
68	0x44	Uint16	16 Bit	C_LowerSeatlift	Counter Lower Seatlift	ro		0	
69	0x45	Uint16	16 Bit	C_UpperSeatlift	Counter Upper Seatlift	ro		0	
70	0x46	Int8	8 Bit signed	Temperature minimal		ro		+100	
71	0x47	Int8	8 Bit signed	Temperature maximal		ro		-100	
72	0x48	Int8	8 Bit signed	Temperature actual		ro		-	

13.1.2.2 Parameter meaning

13.1.2.2.1 Parameter Valve type

Valve type (decimal)	Description IO-Link LIGHT and PREMIUM
0	Double seat valve, normal position open, with cycle, without cycle detection
1	Double seat valve, normal position closed, without cycle
2	Double-seat valve, normal position closed, with cycle only above, without cycle detection
4	Single-seat valve, normal position closed, spring-closing
5	Single-seat valve, normal position closed, air-opening / air-closing
6	Single-seat valve, normal position open, spring-opening
7	Double-seat valve, normal position closed, with cycle, without cycle detection
8	Butterfly valve, normal position closed, spring-closing
9	Butterfly valve, normal position closed, air-opening / air-closing
10	Butterfly valve, normal position open, spring-opening
12	Single-seat valve, normal position open, air-opening / air-closing
13	Butterfly valve, normal position closed, air-opening / air-closing

additionally parameter only for **PREMIUM Version**

Valve type (decimal)	Description
3	Double-seat valve, normal position closed, with cycle, without cycle detection, with teach IN
11	Single seat valve, normal position closed, spring closing, with teach IN
14	Single seat valve. Normal position open, spring opening, with teach IN

13.1.2.2.2 other parameters

Parameter	Function
Brightness TopLed	Brightness settings Top Led; 0-off; 4-maximum brightness
Operation Mode	Operation mode; Bit0 signaling of undefined position suppressed
Fingerprint closed	Stored position pattern "closed" (globe valves)
Fingerprint open	Stored position pattern "open" (globe valves)
Fingerprint lower seatlift	Stored position pattern "cycle bottom" (lift valves)
Fingerprint upper seatlift	Stored position pattern "cycle top" (globe valves)
Angle Closed	Stored angular position "closed" (rotary valves)
Angle Open	Stored angular position "open" (rotary valves)
Tolerance closed	Maximum tolerated deviation from learned position "position closed"
Tolerance open	Maximum tolerated deviation from learned position "position open"
Tolerance lower seat lift	Maximum tolerated deviation from learned position "cycle bottom"
Tolerance upper seatlift	Maximum tolerated deviation from the learned position "cycle top"
Counter power on	Switch-on counter
Counter close	Counter "position closed"
Counter open	Counter "position open"
Counter lower seat lift	Counter "cycle bottom"
Counter upper seatlift	Counter "cycle top"
Temperature minimal	Lowest operating temperature
Temperature maximal	Highest operating temperature
Temperature actual	Current operating temperature

13.1.3 IO-Link commands

IO-Link commands			
Value (dez.)	Value (hex.)	Command	Function
160	A0	Counter reset	Reset all counters
161	A1	Temperature reset	Reset min-max temperature values
162	A2	Start teaching	Learn the valve positions

13.1.4 IO-Link diagnostic messages

IO-Link events					
Value (dez.)	Value (hex.)	Meaning	Occurrence	Type	Cause
6200	1838	Configuration Error	Appear/Disappear	Error	Hardware used for settings inappropriate
6201	1839	Impossible Position	Single shot	Warning	Control for valve type unsuitable
6202	183A	no Fingerprint Data	Appear/Disappear	Error	No or damaged position patterns
6203	183B	Teach error	Appear/Disappear	Error	Learning failed

13.2 Annex 2

13.2.1 Program setting [S]

S	Designation	Function	Process Data		Note
			IN	OUT	
0	Double seat valve with Stroke without Stroke position recognition	Closed	x00	x01	
		Closed	x01	x01	
		Open	x02	x02	
		lower seat lift	x04	x01	
		upper seat lift	x08	x01	
1	Double seat valve piggable without Stroke position recognition	Closed	x00	x01	
		Closed	x01	x01	
		Open	x02	x02	
		lower seat lift	x04	x01	
		upper seat lift	x08	x01	
3	Double seat valve with Stroke position recognition	Closed	x00	x01	
		Closed	x01	x01	
		Open	x02	x02	
		lower seat lift	x04	x04	
		upper seat lift	x08	x08	
		Pulse lower	x10	x04	
		Pulse upper	x20	x08	
4	Lift valve Fail-closed [FC]	Closed	x00	x01	
		Closed	x01	x01	
		Open	x02	x02	
5	Lift valve Double-acting [DA]	Closed	x00	x01	MV 1 activated in basic position
		Closed	x01	x01	
		Open	x02	x02	
6	Lift valve Fail-open [FO]	Open	x00	x02	
		Closed	x01	x01	
		Open	x02	x02	
8	Rotary valve Fail-closed [FC]	Closed	x00	x01	
		Closed	x01	x01	
		Open	x02	x02	
9	Rotary valve Double-acting [DA]	Closed	x00	x01	MV 3 activated in basic position
		Closed	x01	x01	
		Open	x02	x02	
10	Rotary valve Fail-closed [FC]	Open	x00	x02	
		Closed	x01	x01	
		Open	x02	x02	
16	Aseptic-Double seat valve GEMBRA with Stroke position recognition	Closed	x00	x01	
		Closed	x01	x01	
		Open	x02	x02	
		lower seat lift	x04	x04	
		upper seat lift	x08	x08	
17	Aseptic-Double seat valve Bellows Type 587x with Stroke position recognition	Closed	x00	x01	
		Closed	x01	x01	
		Open	x02	x02	
		lower seat lift	x04	x04	
		upper seat lift	x08	x08	
18	Aseptic-Single seat valve Bellows Type 586x	Closed	x00	x01	
		Closed	x01	x01	
		Open	x02	x02	



KIESELMANN GmbH

Paul-Kieselmann-Str. 4-10
D - 75438 Knittlingen

☎ +49(0) 7043 371-0 • 📠 +49(0) 7043 371-125
www.kieselmann.de • info@kieselmann.de

Copyright: © KIESELMANN FLUID PROCESS GROUP