



# KIESELMANN

FLUID PROCESS GROUP

Translation of the original

## Operating Instructions

### Safety valve

Type 6357

Type-examination for liquids and gases



**KIESELMANN GmbH**

Paul-Kieselmann-Str. 4-10  
D - 75438 Knittlingen

 +49(0) 7043 371-0 •  +49(0) 7043 371-125  
[www.kieselmann.de](http://www.kieselmann.de) • [info@kieselmann.de](mailto:info@kieselmann.de)

---

Copyright: © KIESELMANN FLUID PROCESS GROUP

## Table of contents

<b>1</b>	<b>General informations</b>	<b>4</b>
1.1	Informations for your safety	4
1.2	Marking of security instructions	4
1.3	General designated use	4
1.4	Personnel	4
1.5	Modifications, spare parts, accessories	5
1.6	General instructions	5
<b>2</b>	<b>Safety instructions</b>	<b>6</b>
2.1	Intended use	6
2.2	Unintended use	6
2.3	General notes	6
2.4	General safety instructions	6
<b>3</b>	<b>Delivery, transport and storage</b>	<b>8</b>
3.1	Delivery	8
3.2	Transport	8
3.3	Storage	8
<b>4</b>	<b>Function and operation</b>	<b>9</b>
4.1	Description of function	9
4.2	Commissioning, service and maintenance	9
4.2.1	Commissioning	9
4.2.2	Service	10
4.2.3	Cleaning	10
<b>5</b>	<b>Technical data</b>	<b>11</b>
5.1	Safety valve Type 6357	11
5.1.1	Identification	12
5.1.2	Setting range	13
<b>6</b>	<b>Disassembly and assembly</b>	<b>14</b>
6.1	Disassembly	14
6.1.1	DN25 Replacement the product-contaminated seals	16
6.1.2	DN40 - DN100 Replacement the product-contaminated seals	17
6.2	Assembly	18
<b>7</b>	<b>Drawings and dimensions</b>	<b>19</b>
7.1	Safety valve DN 25	19
7.2	Safety valve DN 40 - DN 100	21
<b>8</b>	<b>Wearing parts</b>	<b>23</b>
8.1	Wear parts kit	23
<b>9</b>	<b>Characteristic curves</b>	<b>24</b>
9.1	Opening & closing characteristics	24
9.2	Performance chart	25
<b>10</b>	<b>Classification</b>	<b>31</b>
10.1	Structure of Order Number	31
<b>11</b>	<b>Appendix</b>	<b>33</b>
11.1	Declaration of incorporation	33

# 1 General informations

## 1.1 Informations for your safety

We are pleased that you have decided for a high-class KIESELMANN product. With correct application and adequate maintenance, our products provide long time and reliable operation.





Before installation and initiation, please carefully read this instruction manual and the security advices contained in it. This guarantees reliable and safe operation of this product and your plant respectively. Please note that an incorrect application of the process components may lead to great material damages and personal injury.

In case of damages caused by non observance of this instruction manual, incorrect initiation, handling or external interference, guarantee and warranty will lapse!

Our products are produced, mounted and tested with high diligence. However, if there is still a reason for complaint, we will naturally try to give you entire satisfaction within the scope of our warranty. We will be at your disposal also after expiration of the warranty. In addition, you will also find all necessary instructions and spare part data for maintenance in this instruction manual. If you don't want to carry out the maintenance by yourself, our KIESELMANN - service team will naturally be at your disposal.

## 1.2 Marking of security instructions

Hints are available in the chapter "safety instructions" or directly before the respective operation instruction. The hints are highlighted with a danger symbol and a signal word. Texts beside these symbols have to be read and adhered to by all means. Please continue with the text and with the handling at the valve only afterwards.

Symbol	Signal word	Meaning
	DANGER	Imminent danger which will result severe personal injury or death.
	WARNING	Imminent danger which may result severe personal injury or death.
	CAUTION	Dangerous situation which may cause slight personal injury or material damages.
	NOTICE	An harmful situation which may result in damages of the product itself or of adjacent vicinity.
	INFORMATION	Marks application hints and other information which is particularly useful.

## 1.3 General designated use

The fitting is designed exclusively for the purposes described below. Using the fitting for purposes other than those mentioned is considered contrary to its designated use. KIESELMANN cannot be held liable for any damage resulting from such use. The risk of such misuse lies entirely with the user. The prerequisite for the reliable and safe operation of the fitting is proper transportation and storage as well as competent installation and assembly. Operating the fitting within the limits of its designated use also involves observing the operating, inspection and maintenance instructions.

## 1.4 Personnel

Personnel entrusted with the operation and maintenance of the tank safety system must have the suitable qualification to carry out their tasks. They must be informed about possible dangers and must understand and observe the safety instructions given in the relevant manual. Only allow qualified personnel to make electrical connections.

## **1.5 Modifications, spare parts, accessories**

Unauthorized modifications, additions or conversions which affect the safety of the fitting are not permitted. Safety devices must not be bypassed, removed or made inactive. Only use original spare parts and accessories recommended by the manufacturer.

## **1.6 General instructions**

The user is obliged to operate the fitting only when it is in good working order. In addition to the instructions given in the operating manual, please observe the relevant accident prevention regulations, generally accepted safety regulations, regulations effective in the country of installation, working and safety instructions effective in the user's plant.

## 2 Safety instructions

### 2.1 Intended use

This safety valve is used to prevent overpressure in tanks and vessels in plants of the food and drink industry, pharmaceutical and chemical industries as well as in biotechnology.

### 2.2 Unintended use

Safety valves must not be used improperly. In the event of improper use, the manufacturer is no longer liable.

Seals must not be damaged or removed. Changes may affect the operation and the performance of the safety valve. The guarantee is voided. Moving and functionally important parts must not be given a protective coating.

Safety valves must not be blocked.

Lever on safety valves must not be used as hangers for any objects. The position of the lever must not be changed. No additional weight may be applied to the levers.

### 2.3 General notes



#### NOTICE - observe the operating instructions

To avoid danger and damage, the fitting must be used in accordance with the safety instructions and technical data contained in the operating instructions.



#### NOTICE

All data are in line with the current state of development. Subject to change as a result of technical progress.

### 2.4 General safety instructions



#### ⚠ WARNING

##### Risk of injury by outflowing medium

Dismantling the valve or valve assemblies from the plant can cause injuries.

- Medias flowing through the leakage drain outlet are to be drained off without splashing into a discharge arrangement.
- Carry the disassembling only if when the plant has been rendered pressure-less and free of liquid and gas.



#### ⚠ WARNING

##### Use in EX areas

If the valve or the plant is operated in a potentially explosive atmosphere, the valid directive and the installation instructions in this operating manual must be observed.



#### ⚠ WARNING

##### Risk of injury by outflowing medium

With pressure greater than the set pressure the gaseous or liquid media will radial escape into the atmosphere via outlet drillings.

- It is necessary to install protection and drainage devices.



### **⚠ WARNING**

#### **Changing the set pressure and maintenance-related pressure settings**

Generally, the set pressure can only be reset within the given pressure range.

- It is recommended that the pressure is set by the manufacturer.
  - No liability is assumed for any cases of damage arising from changes to the delivery settings of the fittings.
- ⇒ Generally, any changes to pressure settings on site must be inspected by an authorised institution.



### **⚠ WARNING**

#### **Functional impairment at low temperatures**

Referring to the used sealing materials the safety valves are suitable for a minimum operating temperature at -5 °C.

- Low operating or ambient temperatures may applicable a impairment the function.
  - Therefore, appropriate measures shall be taken for an operation at temperatures below +5°C to ensure a safe function of the valve.



### **⚠ WARNING**

#### **Risk of injury by moving parts**

Do not grab into the valve when the actuator is pressurized. Limbs can be crushing or amputating.

- Remove the control air line before dismantling.
- Ensure that the actuator is unpressurized.



### **⚠ CAUTION**

#### **When mounting the clamps, the max. torque must not be exceeded.**

(see technical data)



### **⚠ CAUTION**

**To avoid air leaking, only use pneumatic connection parts that have an O-ring seal facing the even surface.**



### **⚠ CAUTION**

**Before starting the system, the entire pipeline system must be thoroughly cleaned.**



### **⚠ CAUTION**

#### **Malfunction due to contamination**

Internal or external dirt may impair the function of the fitting or the safety equipment.

- Therefore the fitting must be operated in a way that protects it from external influences.
  - The fitting must be cleaned internal and external at regular intervals.
  - The fitting must be maintained at regular intervals.
  - The fitting must be checked for its function at regular intervals.

## 3 Delivery, transport and storage

### 3.1 Delivery

- Immediately after receipt check the delivery for completeness and transport damages.
- Remove the packaging from the product.
- Retain packaging material, or expose of according to local regulations.

### 3.2 Transport



#### ⚠ CAUTION

##### **Risk of injury and damage to the product**

During the transport the generally acknowledged rules of technology, the national accident prevention regulations and company internal work and safety regulations must be observed.

### 3.3 Storage



#### NOTICE

##### **Damage to the product due to improper storage!**

Observe storage instructions  
avoid a prolonged storage



#### INFORMATION

##### **Recommendation for longer storage**

We recommend regularly checking the product and the prevailing storage conditions during long storage times.

- To avoid damage to seals and bearings,
  - products up to DN 125 / OD 5 inch should be stored horizontally for maximum 6 months.
  - products larger than DN 125 / 5 inch, should be stored in the upright position with the actuator on top.
- Don't store any objects on the products.
- Protect the products for wetness, dust and dirt.
- The product should be stored in a dry and well ventilated room at a constant temperature (optimal indoor temperature: 25 C ±5 ; indoor humidity data 70% ±5%).
- Protect seals, bearings and plastic parts for UV light and ozone.



## 4 Function and operation

### 4.1 Description of function

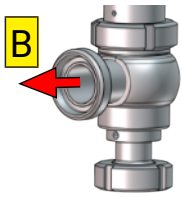

The safety valve is used to prevent inadmissible overpressure of gaseous media in tanks, containers and plant sections.

Generally, the set pressure is greater than the operating pressure. The valve opens against a spring force if the operating pressure increases to the set pressure.

With pressure increase analogous to the opening characteristic, the flow rate is dependent on the max. permissible operating pressure constantly discharged from the outlet drillings (B).

### 4.2 Commissioning, service and maintenance

#### 4.2.1 Commissioning

##### 4.2.1.1 Installation instructions

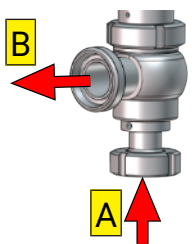

#### Fitting position

Preferably, the safety valve should be installed vertically on connection "A". The valve should be installed so that no fluids remain in the housing.



#### NOTICE

The flow direction is generally in direction of the arrow.

Safety valves with a set pressure  $\leq$  of 0.5 bar are generally installed vertically.

External dynamic effects caused by installation must be avoided.

##### 4.2.1.2 General welding guidelines

Sealing elements integrated in weld components must generally be removed prior to welding. To prevent damage, welding should be undertaken by certified personnel (EN ISO 9606-1). Use the TIG (Tungsten Inert Gas) welding process.



#### CAUTION

#### Damage and injuries due to high temperature supply

To avoid a distortion of the components, all welding parts must be welded to stress-relieved.

Allow all components to cool before assembling.



#### NOTICE

#### Damage due to impurities

Impurities can cause damage to the seals and seals area.

Clean inside areas prior to assembly.

##### 4.2.1.3 Use in EX area

For valves or plants/installations that are operated in the ATEX area, sufficient bonding (grounding) must be ensured. (see e.g. ATEX Directives EC; UKSI 696:2019-Schedule 25)

### 4.2.2 Service



#### RECOMMENDATION

##### Replacement of seals

To achieve optimal maintenance cycles, the following points must be observed!

- When replacement of seals, all product-contacting seals should be replaced.
- Only original spare parts may be installed.

##### Maintenance interval

The maintenance intervals depend on the operating conditions "temperature, temperature-intervals, medium, cleaning medium, pressure and opening frequency". We recommend replacing the seals 1-year cycle. The user, however should establish appropriate maintenance intervals according to the condition of the seals.

##### Lubricant recommendation

	EPDM; HNBR; NBR; FKM; k-flex	-	Klüber Paraliq GTE703*
	Silicone	-	Klüber Sintheso pro AA2*
	Thread	-	Interflon Food*
<p>*) It is only permitted to use approved lubricants, if the respective fitting is used for the production of food or drink. Please observe the relevant safety data sheets of the manufacturers of lubricants.</p>			

### 4.2.3 Cleaning

For best cleaning results, keep the valve open during cleaning, whereby the seals, the parts in contact with the product and their surfaces must be completely rinsed.

## 5 Technical data

### 5.1 Safety valve Type 6357

Model	Safety valve <ul style="list-style-type: none"> <li>• Type-examination for liquids and gases</li> </ul>	
Valve size	DN25 - DN100	
Connection	Standard:	<ul style="list-style-type: none"> <li>• Liner / nut DIN 11851</li> <li>• Male part DIN11851</li> </ul>
	Optional:	<ul style="list-style-type: none"> <li>• KK Small flange</li> <li>• Hygienic - groove-faced/liner flange DIN 11853-2</li> <li>• Hygienic - Clamp DIN 11853-2</li> <li>• Clamp DIN 32676</li> <li>• APV Flange</li> <li>• VARIVENT® Groove-faced/ liner flange</li> <li>• Flange PN6 / PN10 / PN10/16</li> </ul>
Control air pressure	5,5 - 8,0 bar	
Leak rate	A (EN 12266-1)	
Quality of control air:	ISO 8573-1 : 2001 quality class 3	

Temperature range	Ambient temperature:	+4° to +45°C
	(air)	
	Operating temperature:	-5° to +100°C
	(medium dependent)	
	Sterilization temperature:	HNBR +130°C
	(SIP 30 min)	EPDM +140°C
		FKM +110°C

Material: (in product contact)	stainless steel:	1.4404 / AISI 316L
	Surface:	Ra ≤ 0,8µm
	Sealing material:	<ul style="list-style-type: none"> <li>• HNBR</li> <li>• EPDM</li> <li>• FKM</li> </ul>

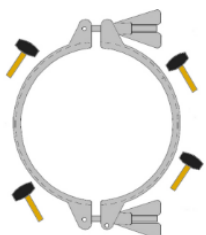

#### Tightening moment

DN	25	40	50	65	80	100
Inch	1	1½	2	2½	3	4
<b>Clamp coupling (Nm):</b>	-	20	20	20	20	27

5.1.1 Identification

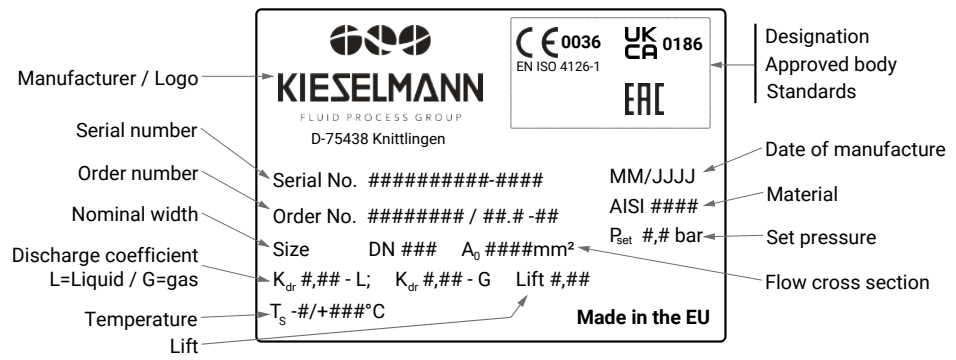

## 5.1.2 Setting range





Item number	Nom- inal width	Adjusting range	$\alpha$ -value	$\alpha$ -value	narrowest flow area	Inlet	Outlet
			Kdr -L	Kdr -G			
			fluid	gas			
		(bar)			do	d1	d2
					Ø (mm)	Ø (mm)	Ø (mm)
6357 025 x23 - 16x	25	0.2 - 0.4	0.38	0.43	26	26	32
6357 025 x23 - 11x		0.5 - 0.9	0.38	0.43			
6357 025 x23 - 11x		1.0 - 1.5	0.41				
6357 025 x23 - 12x		1.6 - 2.0	0.42	0.46*			
		2.1 - 2.5	0.44				
6357 025 x23 - 13x		2.6 - 3.0	0.41	0.42*			
		3.1 - 4.5	0.47				
6357 025 x23 - 14x		4.6 - 7.0	0.45	0.35*			
6357 025 x23 - 15x	7.1 - 12.0	0.40	0.35*				
6357 040 x23 - 11x	40	0.2 - 1.0	0.50	0.55	32	38	38
6357 040 x23 - 12x		1.1 - 1.4	0.39	0.50			
		1.5 - 2.4	0.46				
		2.5 - 3.0	0.48				
6357 040 x23 - 13x		3.1 - 4.4	0.38	0.43			
		4.5 - 7.0	0.44				
6357 040 x23 - 14x	7.1 - 12.0	0.35	0.30				
6357 050 x23 - 11x	50	0.3 - 0.9	0.55	0.55	38	50	50
6357 050 x23 - 12x		1.0 - 1.4	0.52	0.50			
		1.5 - 1.7	0.61	0.55			
6357 050 x23 - 13x		1.8 - 2.9	0.65	0.60			
6357 050 x23 - 14x		3.0 - 6.0	0.52	0.50			
6357 050 x23 - 15x		6.1 - 7.9	0.41	0.35			
		8.0 - 9.9	0.44				
	10.0 - 12.0	0.48					
6357 065 x23 - 11x	65	0.4 - 0.9	0.39	0.42	50	66	66
6357 065 x23 - 12x		1.0 - 1.5	0.52	0.55			
		1.6 - 2.0	0.49	0.52			
6357 065 x23 - 13x		2.1 - 3.0	0.54	0.46			
		3.1 - 7.0	0.54	0.46			
6357 065 x23 - 14x	7.1 - 9.0	0.53	0.46				
6357 080 x23 - 11x	80	0.3 - 0.9	0.47	0.47	66	81	81
6357 080 x23 - 12x		1.0 - 1.9	0.50	0.45			
6357 080 x23 - 13x		2.0 - 3.3	0.50	0.45			
6357 080 x23 - 14x		3.4 - 4.3	0.50	0.44			
6357 080 x23 - 15x		4.4 - 6.2	0.43	0.36			
		6.3 - 8.0	0.50				
6357 100 x23 - 11x	100	0.3 - 1.1	0.36	0.41	81	100	100
6357 100 x23 - 12x		1.2 - 1.8	0.37	0.41			
6357 100 x23 - 13x		1.9 - 2.4	0.37	0.32			
		2.5 - 3.2	0.44				

\*) For the Media group Gas (G), the requirements from the EN 4126-1 have not been complied, respective to the closing pressure difference. The data were determined and certified by TÜV.

## 6 Disassembly and assembly

### 6.1 Disassembly

#### Mounting tools

T1		Combination wrench-Set	SW 8 - SW 24	-
T10		Joint -pin wrench	Pin Ø6	8027000065-000
T11		Hinged hook wrench	DN25 - DN100 90/155 V2A	8028025100-020
T30		Needle	-	-



#### NOTICE

All threaded joint have right-hand thread.

Disconnect the control air, electrical lines, hood or feedback unit and manual or pneumatic lifting device.

#### Disassemble hood (H)

- Unscrew hood (H) and remove O-ring (D5).

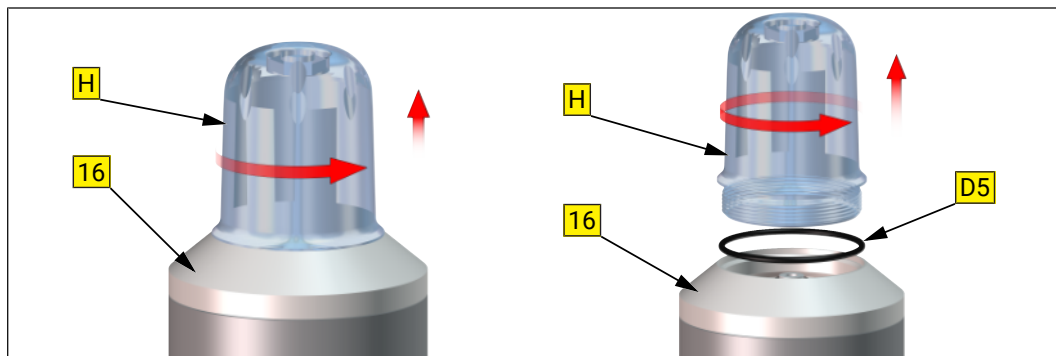

#### Disassemble manual lifting device

- Dismantle the circlip (24.2). Remove the pin (24.1) from lever (24). Pull off the lever (24) from rod (20). Remove disc (23).
- Unscrew the hood (25). Remove O-ring (D5), pressure spring (21) and spring guide (19).
- Dismantle dowel pin (18) and remove rod (20) from piston rod (9.1).

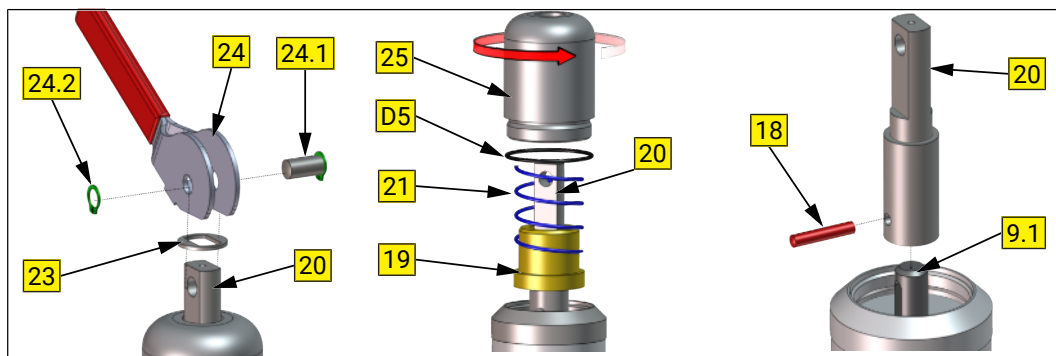

**Disassemble feedback unit**

- Unscrew the electrical line (EL) from sensor (S).
- Unscrew the hood (H). Remove O-ring (D5).
- Unscrew the screw (S3) and remove the bracket (S2).

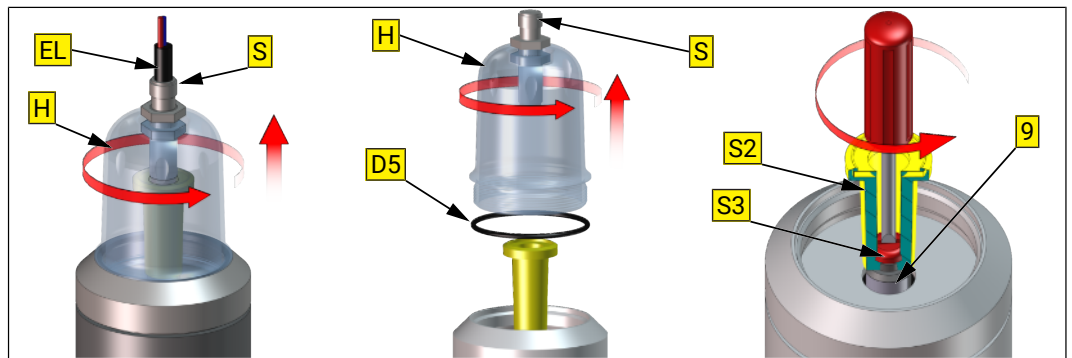

6.1.1 DN25 Replacement the product-contaminated seals

Replacement of seals: Shaft seal (D4), O-Rings (D1), (D2), (D3)



**NOTICE**

Without removing the Safety label (SE) and changing the set pressure.

Unscrew the slotted nut (N) from the housing (1).  
Dismantle the complete valve insert from the housing (1).

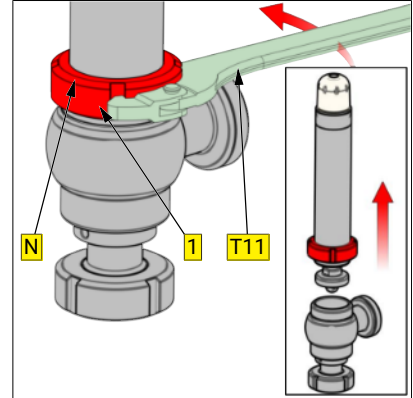

Unscrew the housing (1) from the screw-in socket (2) and remove the O-ring (D2).

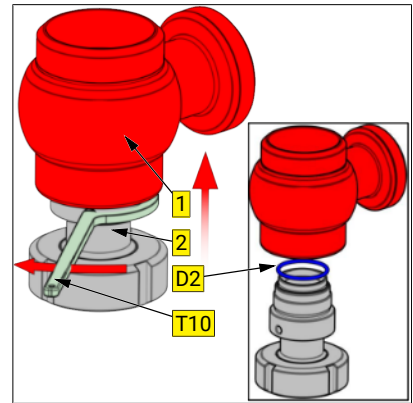

Unscrew the piston plate (4) from the piston (5) - (SW1) / (SW2).

Remove O-ring (D1).

Remove the piston (5) and piston rod (9) axially out of the housing (11).

Remove O-ring (D3).

Puncture the scraper ring (D4) at the centre with a pointed tool (T30) and remove them from the groove.

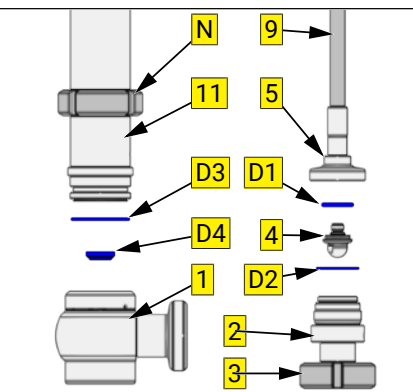
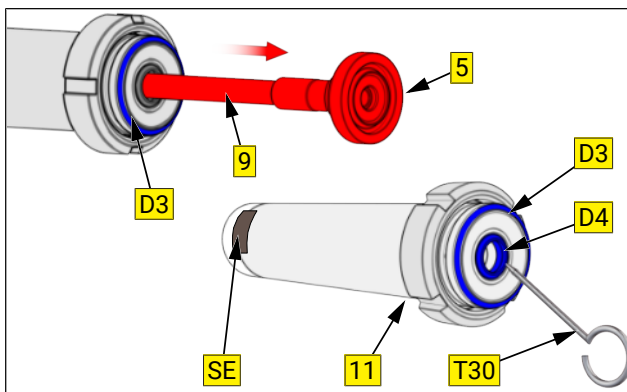
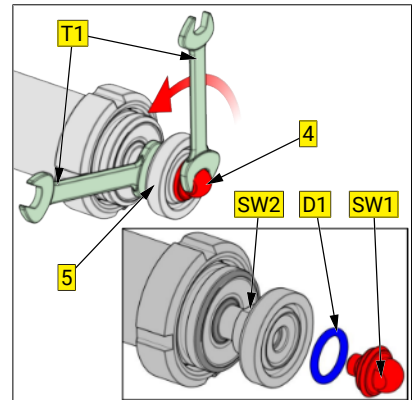



### 6.1.2 DN40 - DN100 Replacement the product-contaminated seals

#### Replacement of seals: Shaft seal (D4), O-Rings (D1), (D2), (D3)



#### NOTICE

Without removing the Safety label (SE) and changing the set pressure.

Unscrew the clamp coupling (VK).  
Dismantle the complete valve insert from the housing (1).

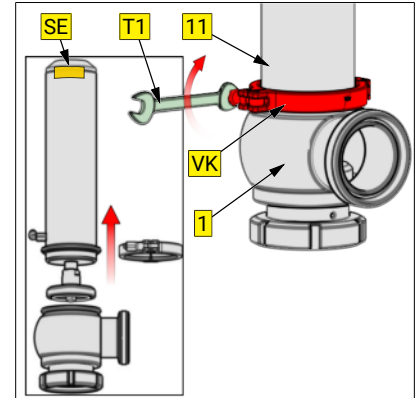

Unscrew the housing (1) from the screw-in socket (2) and remove the O-ring (D2).

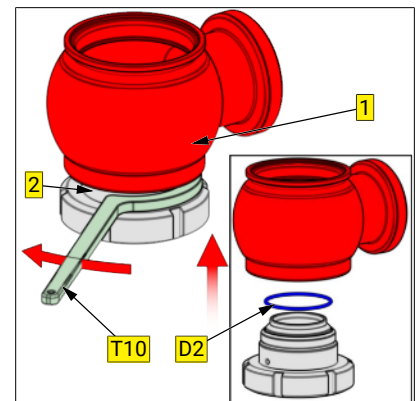

Unscrew the piston plate (4) from the piston (5) - (SW1) / (SW2).  
Remove O-ring (D1).

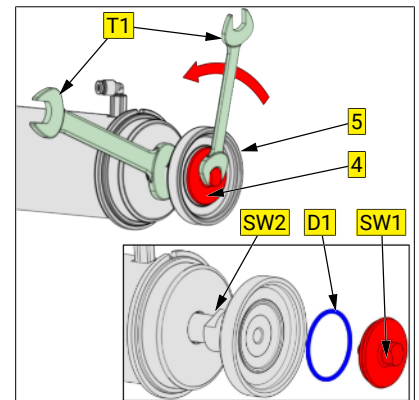

Unscrew the piston (5) from the piston rod (9) - (SW2) / (SW3).

Remove the piston (5) and piston rod (9) axially out of the housing (11).

Remove O-ring (D3).

Puncture the scraper ring (D4) at the centre with a pointed tool (T30) and remove them from the groove.

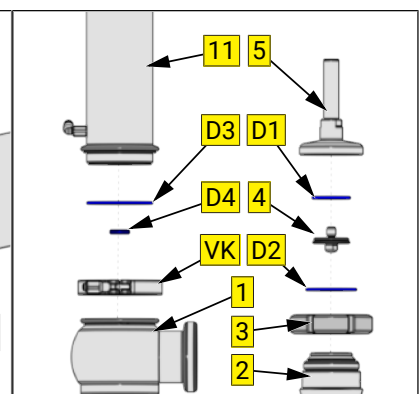
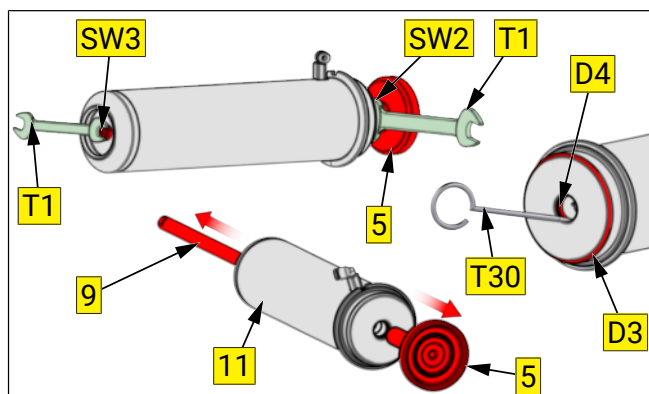

## 6.2 Assembly

- Before installation, thoroughly clean and slightly lubricate mounting areas and running surfaces.
- Assemble in reverse order.



### NOTICE

Alternately press and roll the O-rings into the groove with round body.

### Performance test

- Check the function according to the specified performance data in the operating state.

## 7 Drawings and dimensions

### 7.1 Safety valve DN 25

DN25 Basic design	manual	pneumatic operation
-------------------	--------	---------------------

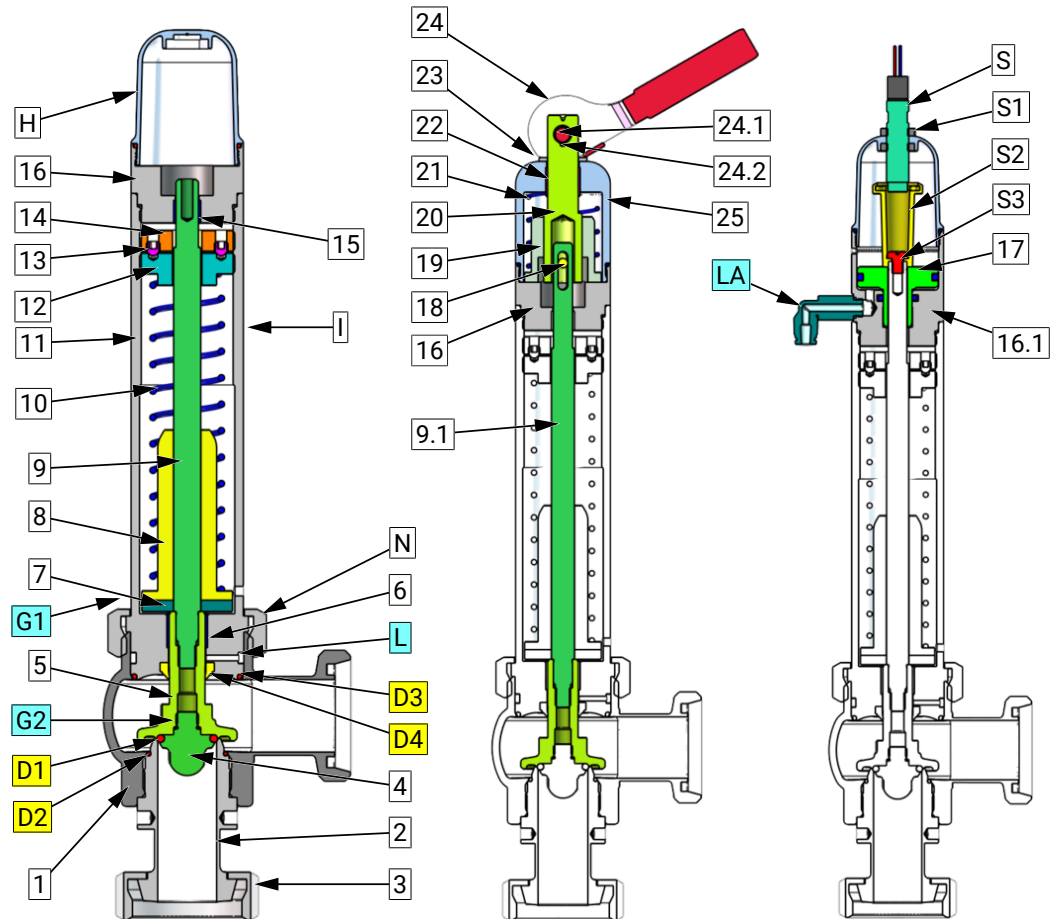

1 Housing	2 Screw-in socket
3 Slotted nut	4 Piston plate
5 Piston	6 Slide bearing
7 Spring disc	8 Spring guide
9 Piston rod	9.1 Piston rod (manual operation)
10 Compression spring	11 Spring housing
12 Setting disc	13 Headless pin
14 locking disc	15 Slide bearing
16 Cover	16.1 Cover
17 Piston	18 Dowel pin
19 Spring guide	20 Shaft
21 Compression spring	22 Slide bearing
23 Washer	24 lever
24.1 bolt/Bolddbolt	24.2 Retaining ring
25 Hood (manual operation)	D1 O-ring
D2 O-ring	D3 O-ring
D4 Scraper ring	G1 Screw retention detachable (e.g. Loctite 243)
G2 Screw retention high-strength (e.g. Loctite 2701)	H Cap
I Identification	L Leakage drain
LA Air connection	N Slotted nut
S sensor	S1 Nut
S2 Jacket + pulse generator	S3 Screw

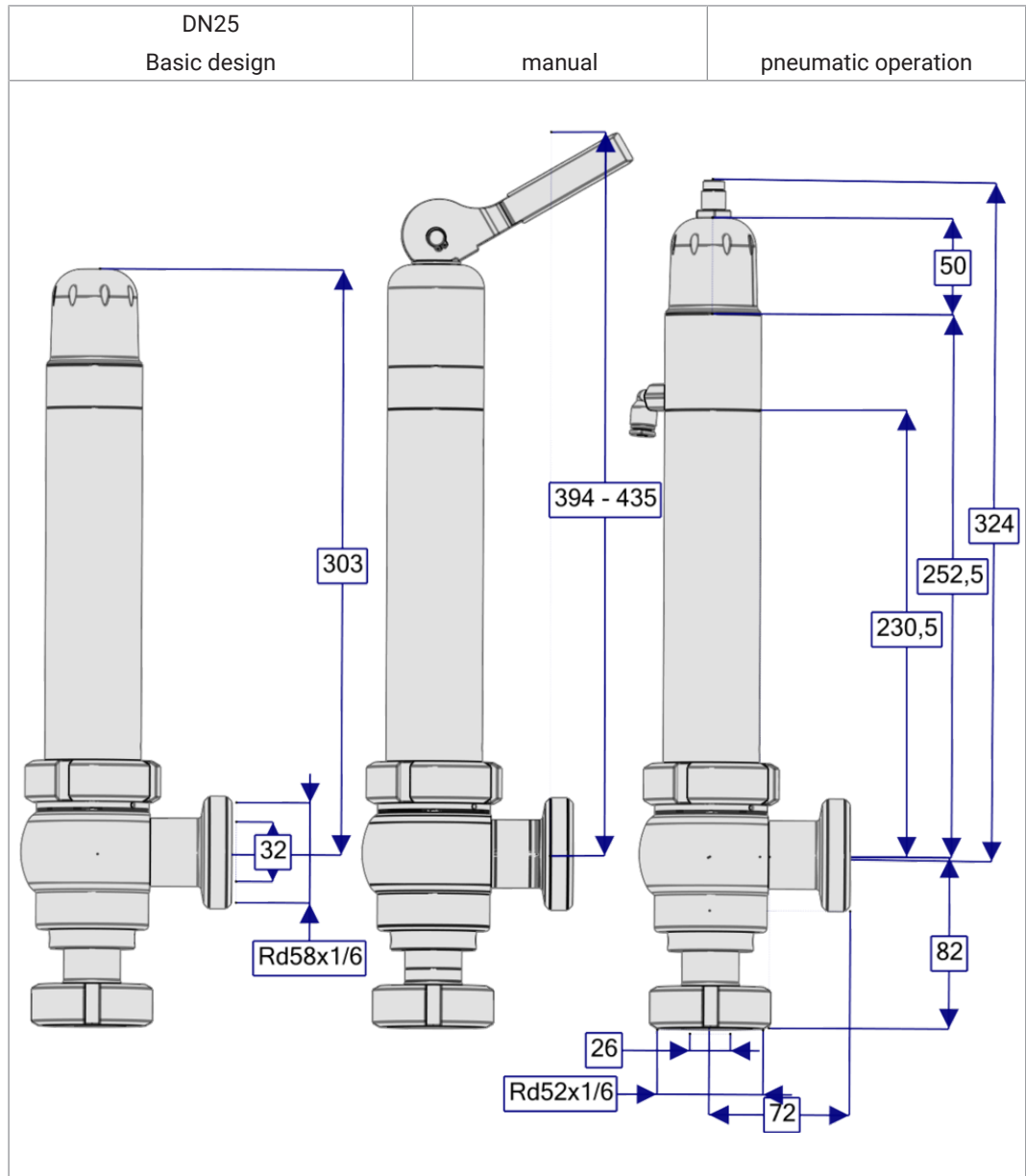

### 7.2 Safety valve DN 40 - DN 100

DN40 - DN100 Basic design	manual	pneumatic operation
---------------------------	--------	---------------------

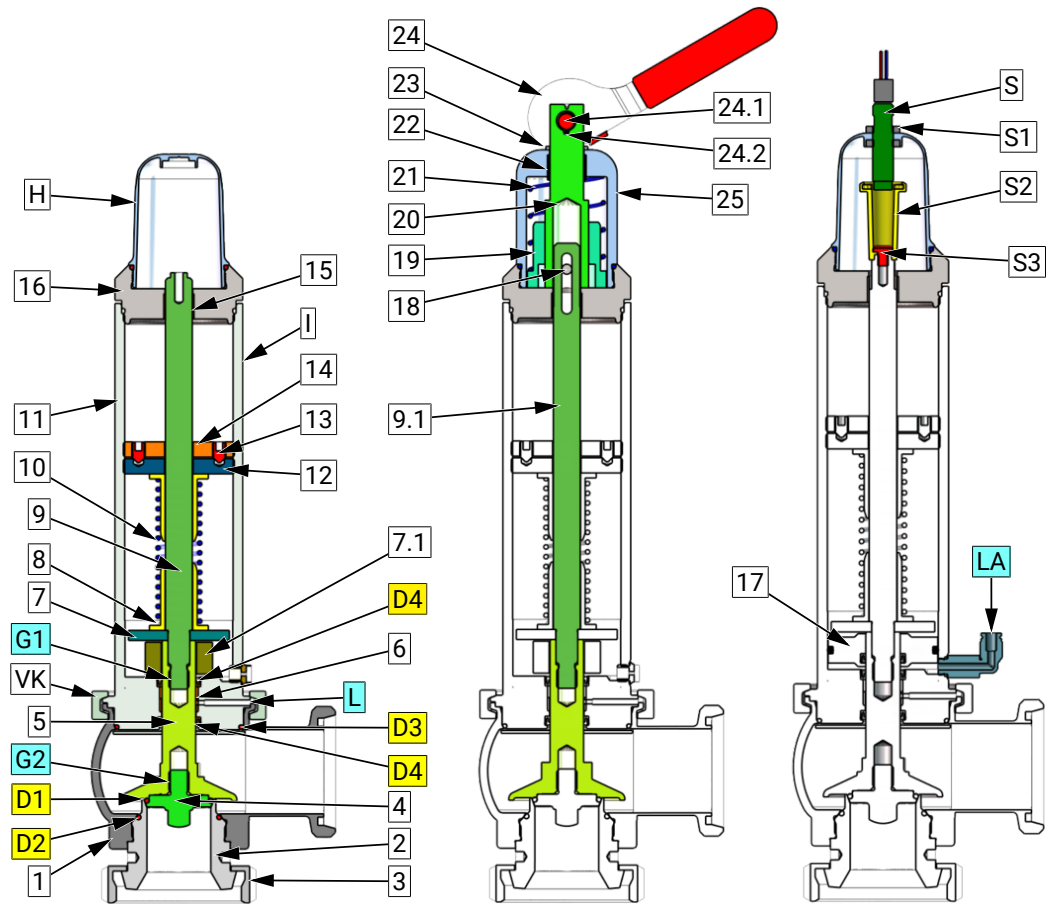

1 Housing	2 Screw-in socket
3 Slotted nut	4 Piston plate
5 Piston	6 Slide bearing
7 Spring disc	7.1 Distance
8 Spring guide	9 Piston rod
9.1 Piston rod (manual operation)	10 Compression spring
11 Spring housing	12 Screw-in socket
13 Headless pin	14 locking disc
15 Slide bearing	16 Cover
17 Piston	18 Dowel pin
19 Spring guide	20 Shaft
21 Compression spring	22 Slide bearing
23 Washer	24 lever
24.1 bolt	24.2 Retaining ring
25 Hood (manual operation)	D1 O-ring
D2 O-ring	D3 O-ring
D4 Scraper ring	G1 Screw retention detachable (e.g. Loctite 243)
G2 Screw retention high-strength (e.g. Loctite 2701)	H Cap
I Identification	L Leakage drain
LA Air connection	S sensor
S1 Nut	S2 Jacket + pulse generator
S3 Screw	VK Locking clip

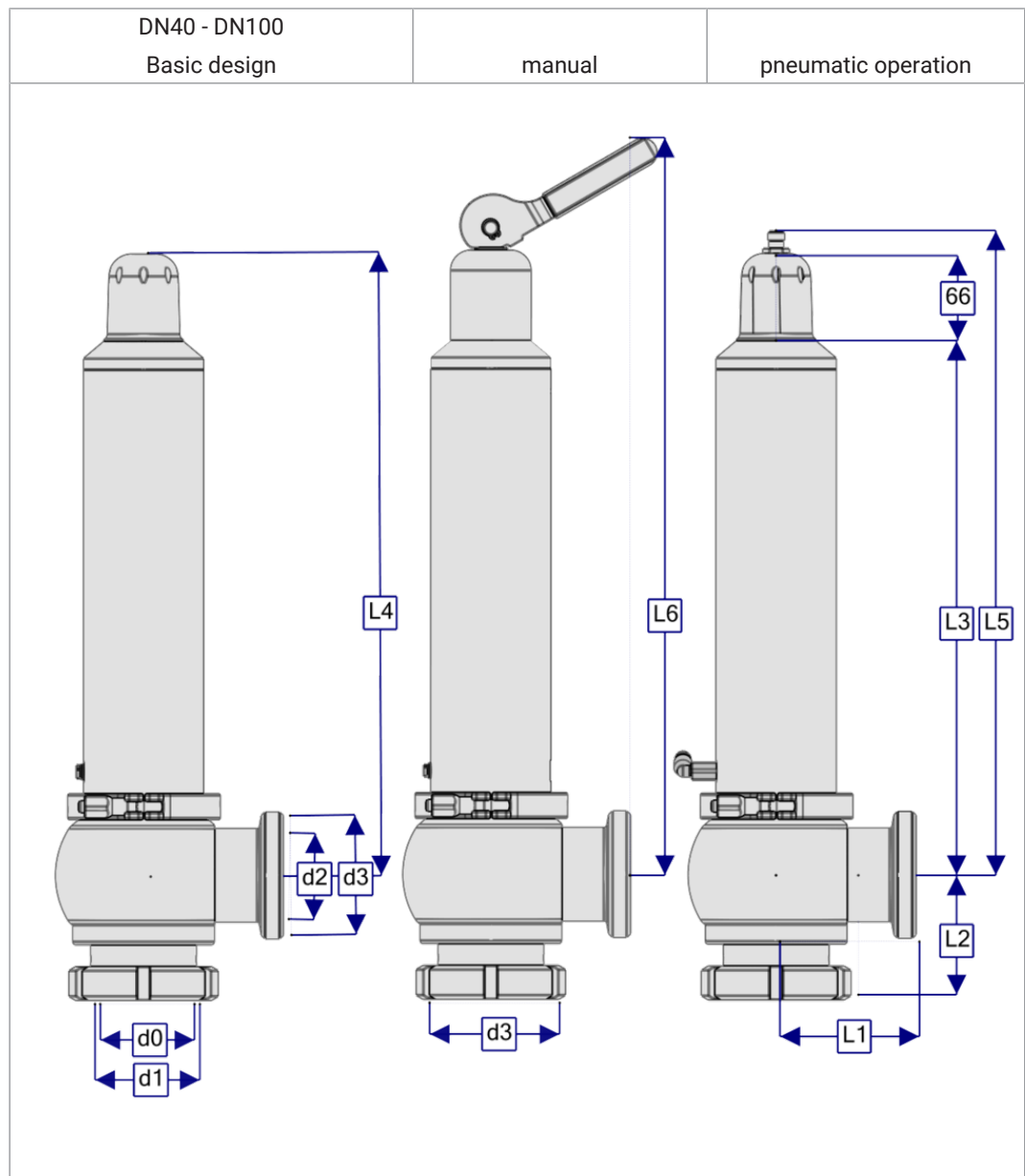

DN	d0	d1	d2	d3	L1	L2	L3	L4	L5	L6
40	32	38	38	Rd65x1/6	82	68	255	320	338	407 - 487
50	38	50	50	Rd78x1/6	93	70	301	367	384	455 - 535
65	50	66	66	Rd95x1/6	105	85	402	467	484	555 - 635
80	66	81	81	Rd110x1/4	115	100	407.5	473.5	489	560 - 640
100	81	100	100	Rd130x1/4	130	130	418	484	501	570 - 650

## 8 Wearing parts

### 8.1 Wear parts kit

Wear part sets	
EPDM	6357 DN 100-100
HNBR	6357 DN 100-200
FKM	6357 DN 100-300

DN = Nominal diameter e.g. DN 40 - 6357 040 100-000

DN	Material	Wear part set	Pos. D1 O-ring (1x)	Pos. D2 O-ring (1x)	Pos. D3 O-ring (1x)	Pos. D4 Scraper ring DN25 L-Seal $\geq$ DN40/1½
25 1"	EPDM	6357 025 100-100	2304 019 035-170	2304 030 020-170	2304 042 025-170	2330 016 007-054 (1x)
	HNBR	6357 025 100-200	2304 019 035-171	2304 030 020-171	2304 042 025-171	2330 016 007-171
	FKM	6357 025 100-300	2304 019 035-051	2304 030 020-251	2304 042 025-251	2330 016 007-251
40 1½"	EPDM	6357 040 100-100	2304 027 030-170	2304 035 030-170	2304 069 026-159	2331 020 050-054 (1x)
	HNBR	6357 040 100-200	2304 027 030-171	2304 035 030-171	2304 069 026-171	2331 020 050-171
	FKM	6357 040 100-300	2304 027 030-251	2304 035 030-051	2304 069 026-251	2331 020 050-051
50 2"	EPDM	6357 050 100-100	2304 035 030-170	2304 042 030-170	2304 069 026-159	2331 020 050-054 (2x)
	HNBR	6357 050 100-200	2304 035 030-171	2304 042 030-171	2304 069 026-171	2331 020 050-171
	FKM	6357 050 100-300	2304 035 030-051	2304 042 030-251	2304 069 026-251	2331 020 050-051
65 2½"	EPDM	6357 065 100-100	2304 046 030-170	2304 064 025-054	2304 082 026-159	2331 020 050-054 (2x)
	HNBR	6357 065 100-200	2304 046 030-171	2304 064 025-171	2304 082 026-171	2331 020 050-171
	FKM	6357 065 100-300	2304 046 030-051	2304 064 025-051	2304 082 026-051	2331 020 050-051
80 3"	EPDM	6357 080 100-100	2304 060 030-170	2304 069 035-170	2304 098 035-170	2331 020 050-054 (2x)
	HNBR	6357 080 100-200	2304 060 030-171	2304 069 035-171	2304 098 035-171	2331 020 050-171
	FKM	6357 080 100-300	2304 060 030-251	2304 069 035-051	2304 098 035-051	2331 020 050-051
100 4"	EPDM	6357 100 100-100	2304 075 040-170	2304 094 025-054	2304 117 035-159	2331 020 050-054 (2x)
	HNBR	6357 100 100-200	2304 075 040-171	2304 094 025-171	2304 117 035-171	2331 020 050-171
	FKM	6357 100 100-300	2304 075 040-251	2304 094 025-051	2304 117 035-051	2331 020 050-051

## 9 Characteristic curves

### 9.1 Opening & closing characteristics

#### Opening and closing characteristics

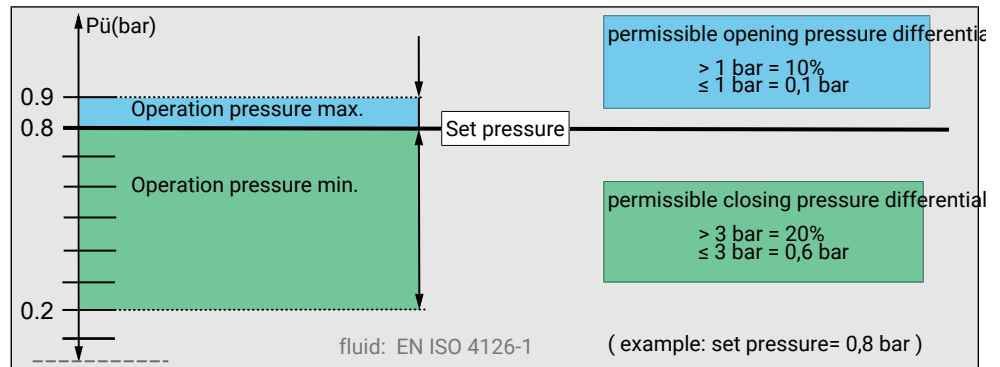

Fig. 1

- Opening and closing characteristics for gas (air) 20°C

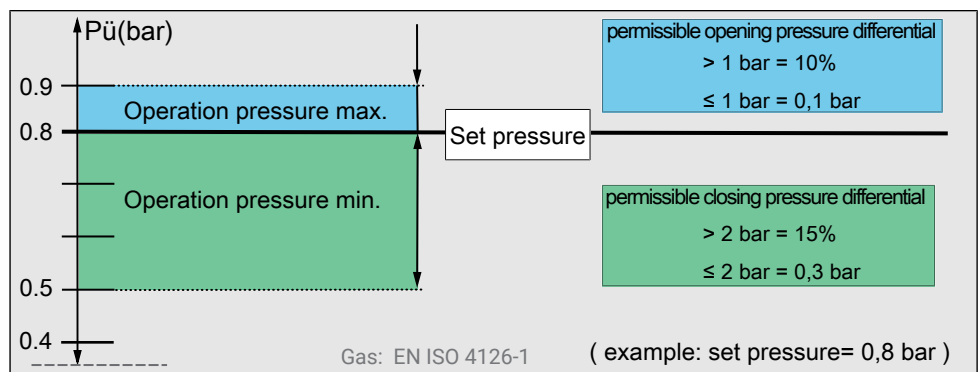
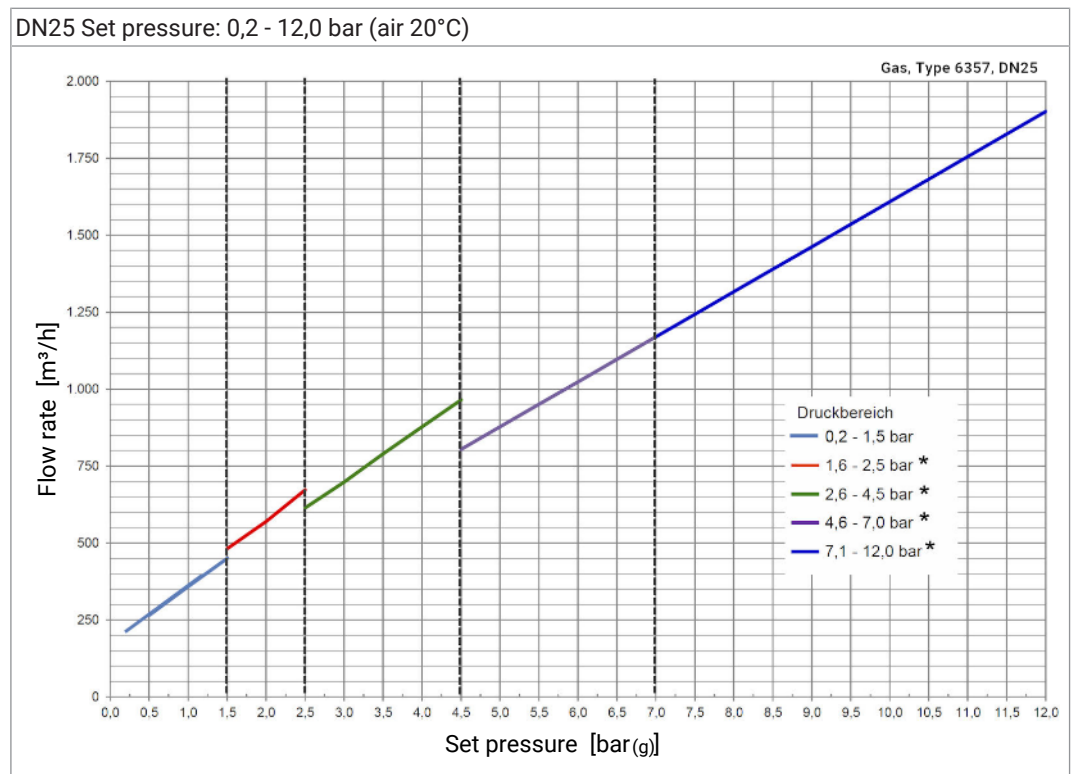
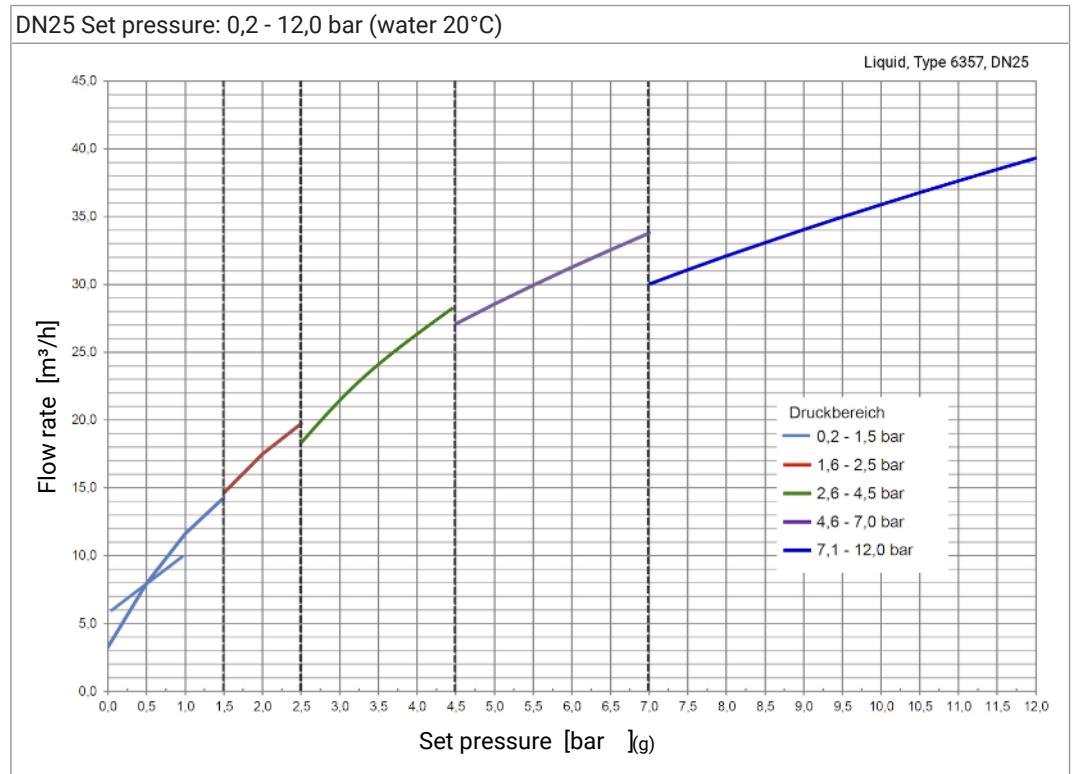

Fig. 2



## 9.2 Performance chart

### Performance chart nominal diameter 25



\*) For the Media group Gas (G), the requirements from the DIN EN 4126-1 have not been complied, respective to the closing pressure difference.

The data were determined and certified by TÜV.

**Performance chart nominal diameter 40**

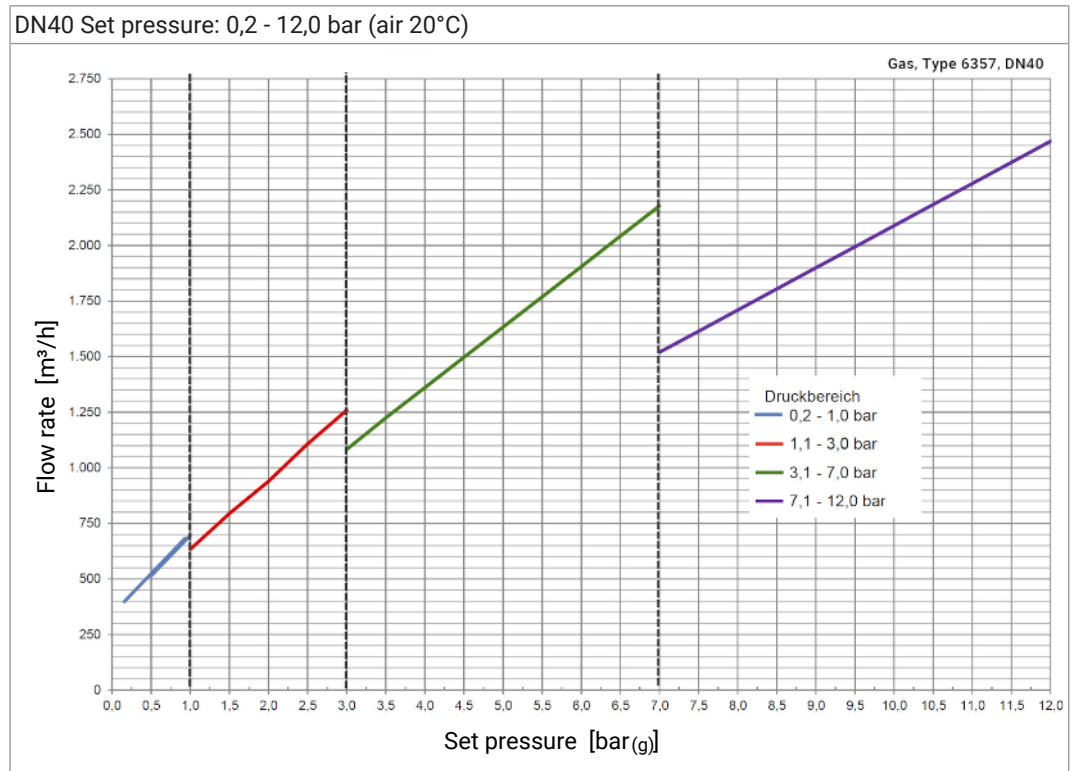
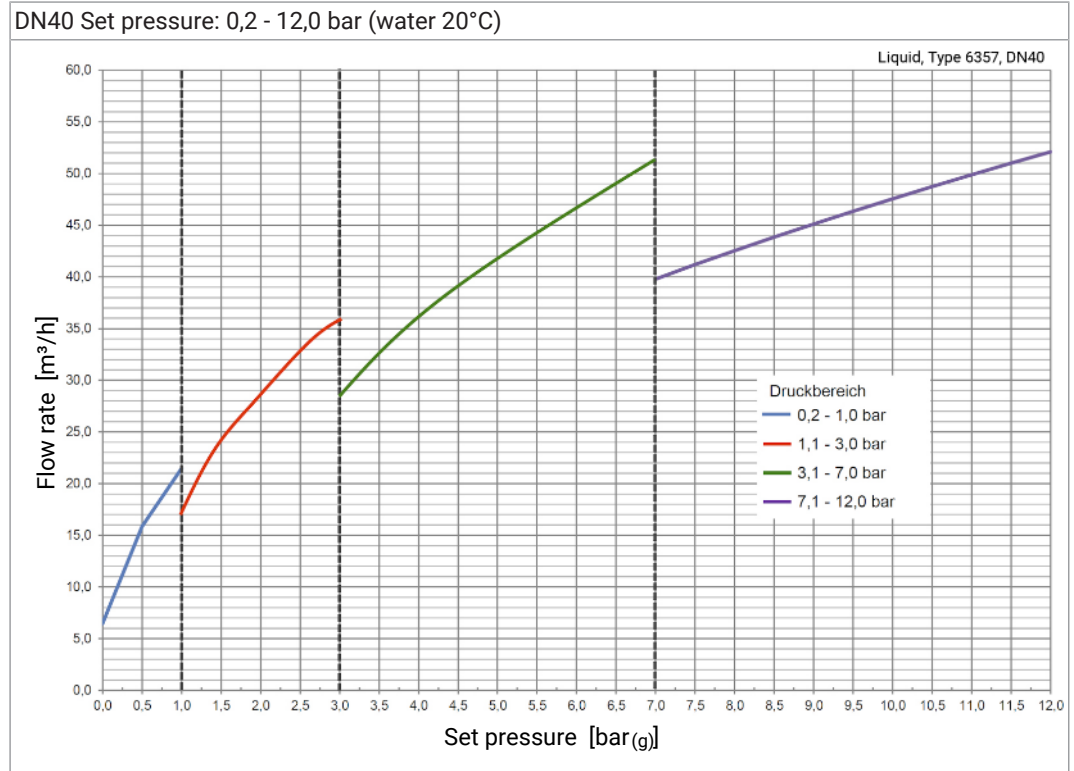

**Performance chart nominal diameter 50**

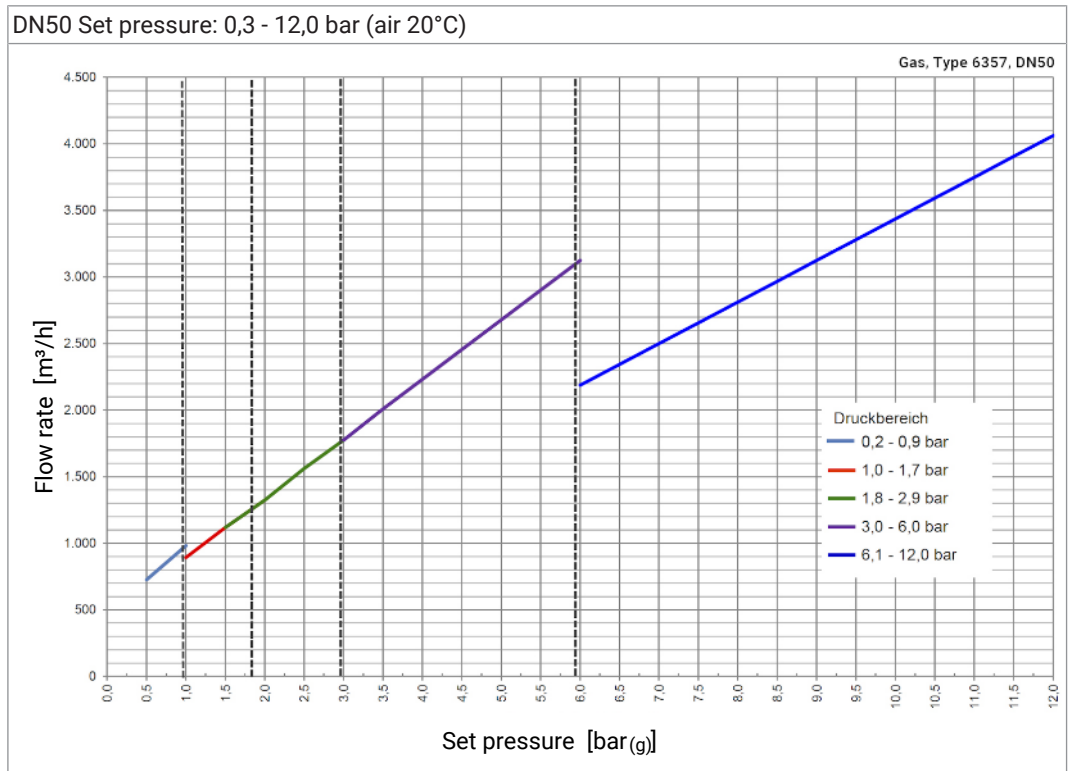
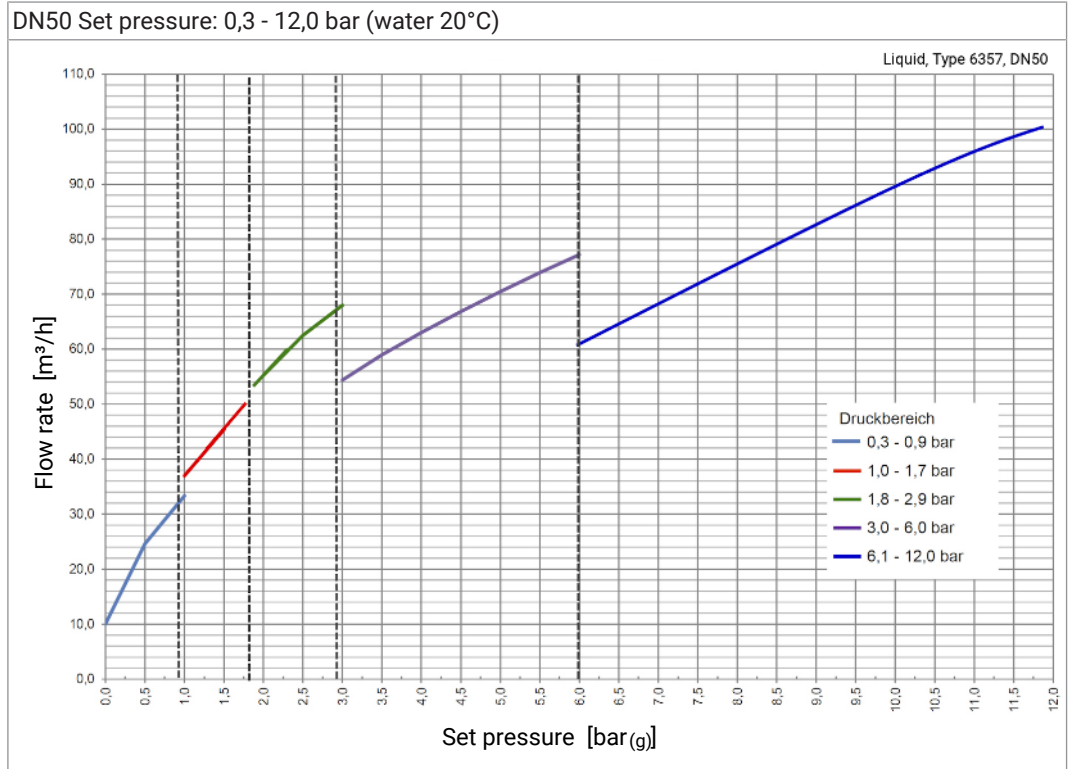

**Performance chart nominal diameter 65**

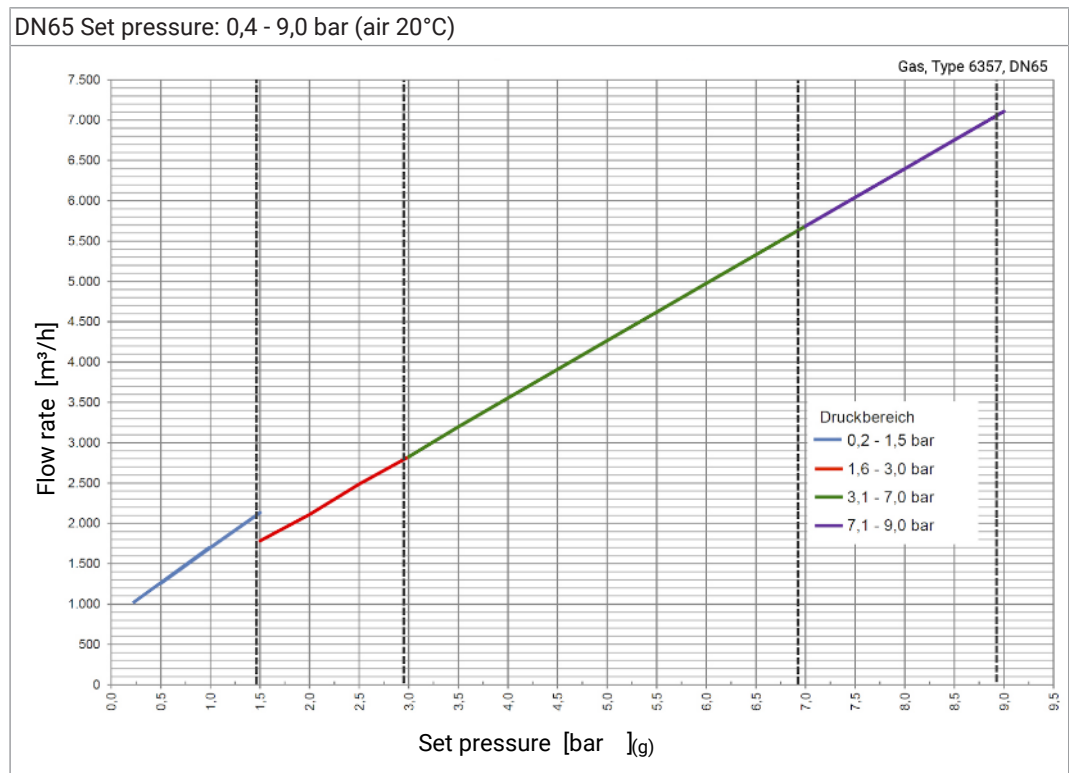
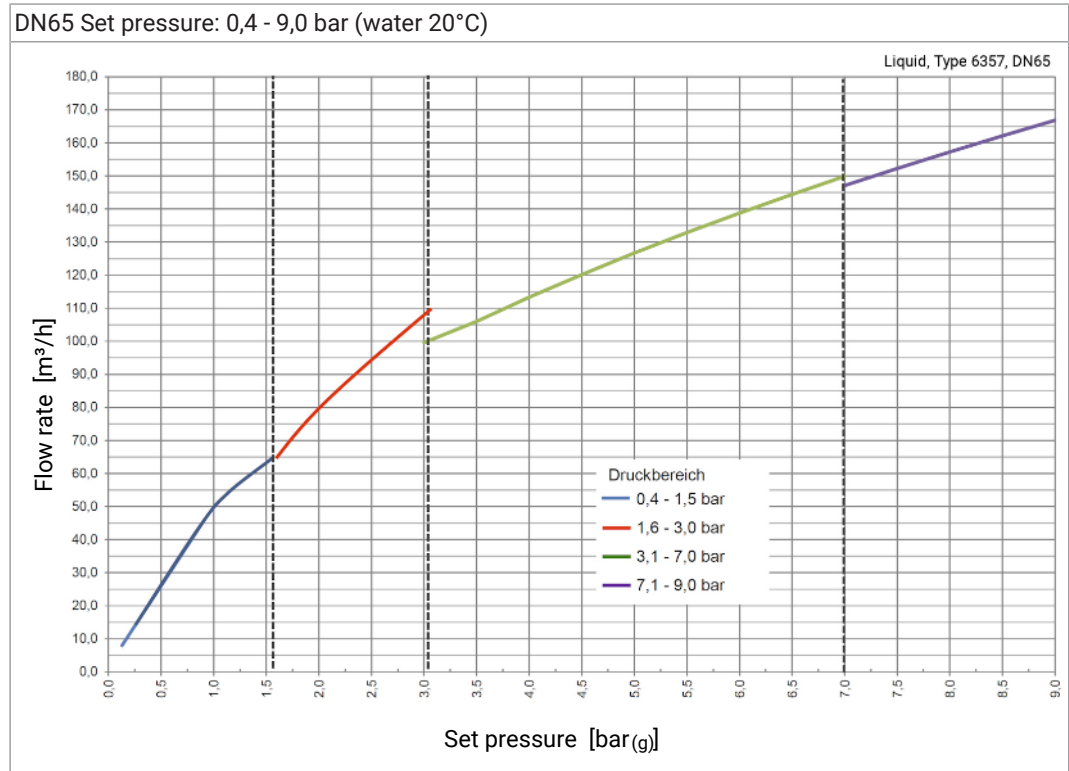

**Performance chart nominal diameter 80**

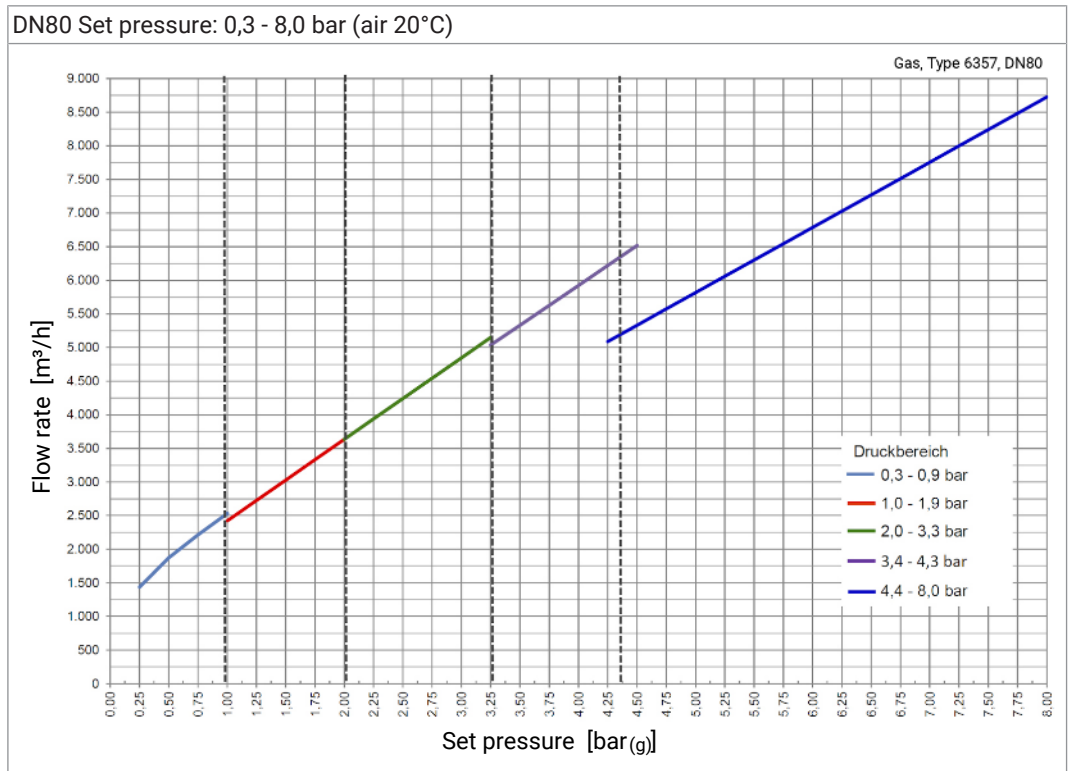
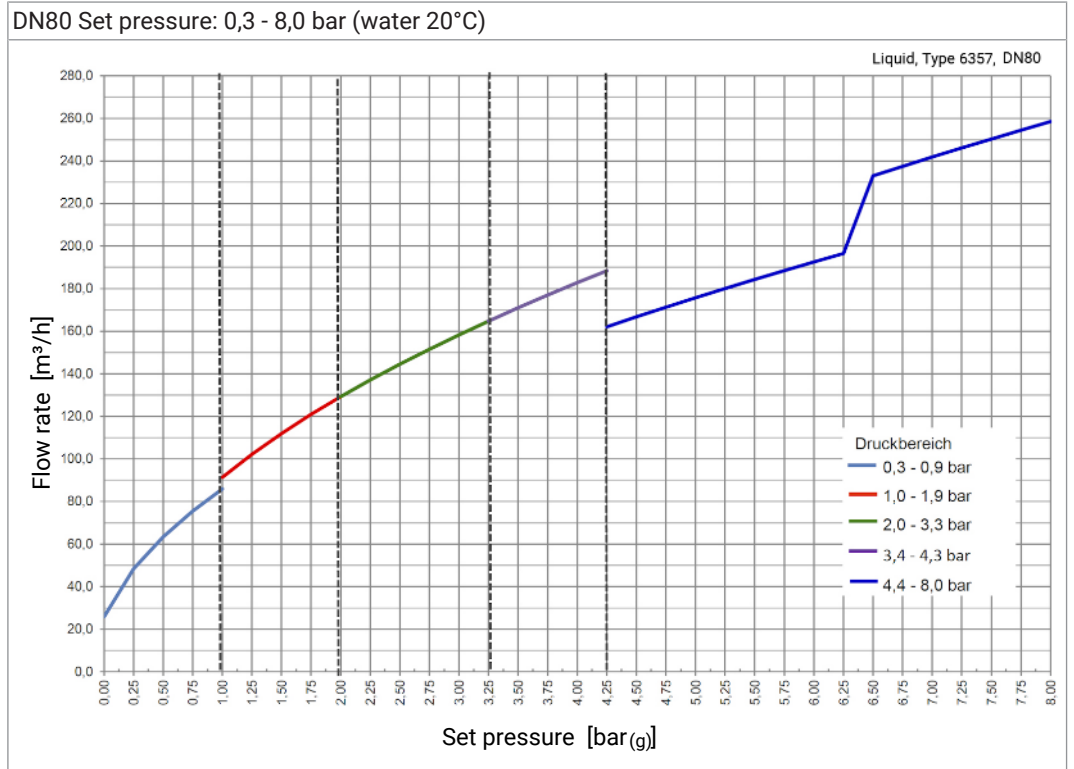

**Performance chart nominal diameter 100**

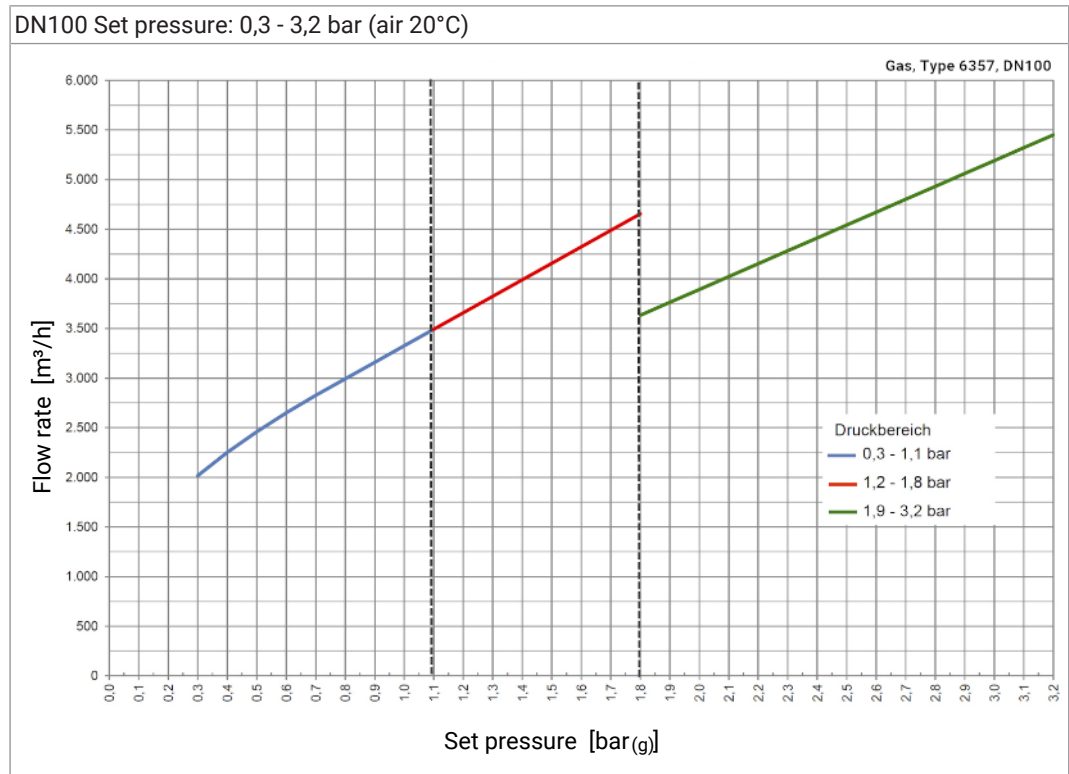
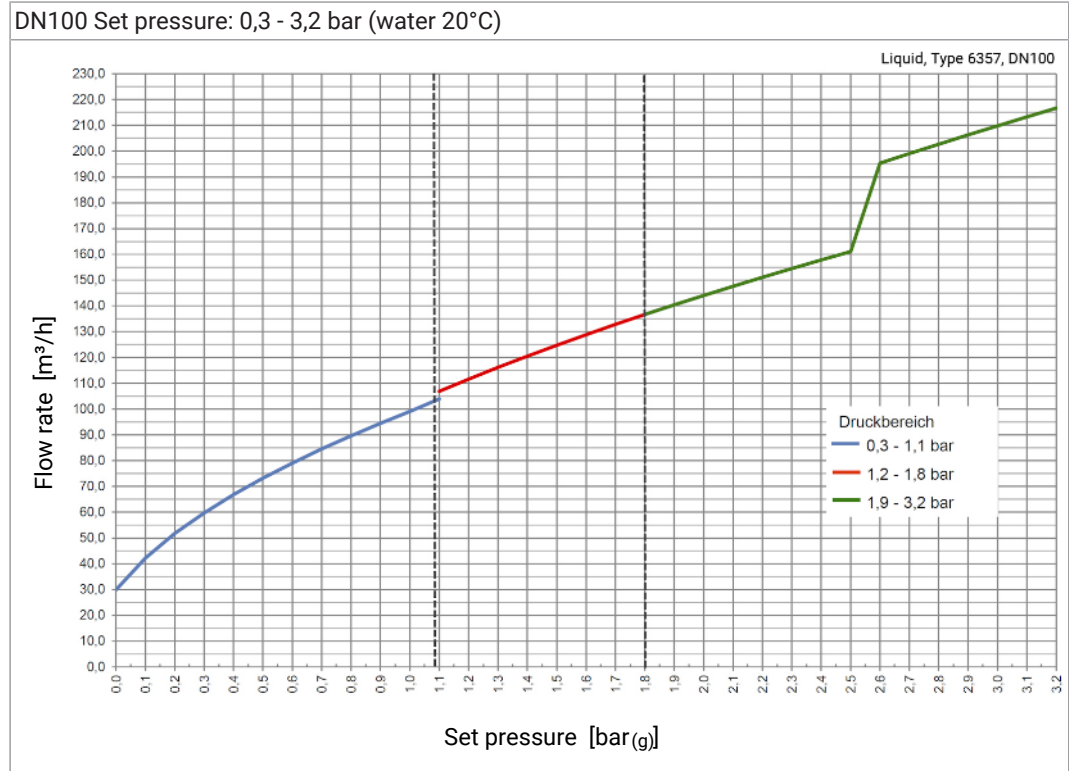

# 10 Classification

## 10.1 Structure of Order Number

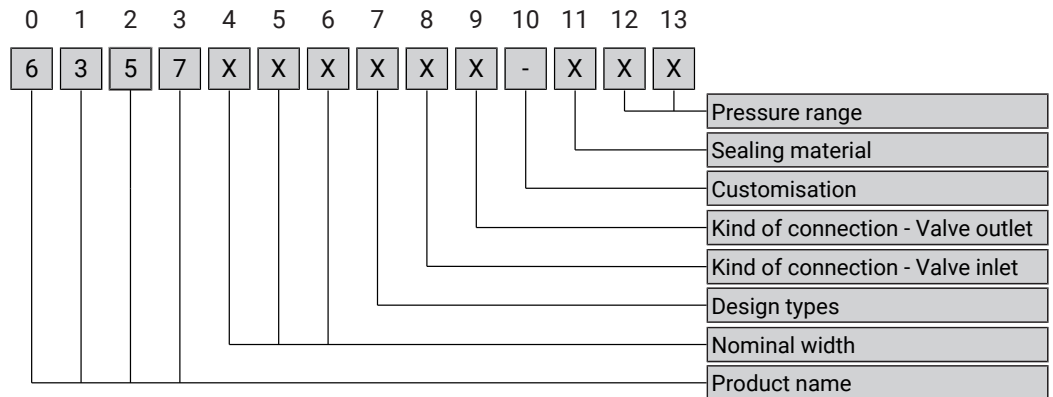

### Product name

<b>6357</b> xxx xxx-xxx				
Designation	Pos. 0	Pos. 1	Pos. 2	Pos. 3
Safety valve	6	3	5	7

### Nominal width

xxxx XXX xxx-xxx								
DN	Pos. 4	Pos. 5	Pos. 6	OD	Pos. 4	Pos. 5	Pos. 6	
DN 25	0	2	5	OD 1"	0	2	6	
DN 40	0	4	0	OD 1 1/2"	0	3	8	
DN 50	0	5	0	OD 2"	0	5	1	
DN 65	0	6	5	OD 2 1/2"	0	6	4	
DN 80	0	8	0	OD 3"	0	7	6	
DN 100	1	0	0	OD 4"	1	0	1	
DN 125	1	2	5	OD 5"	1	2	7	
DN 150	1	5	0	OD 6"	1	5	2	

### Design types

xxxx xxx <b>X</b> xx-xxx	
Model	Pos. 7
Single parts	0
Standard	1
Standard with feedback unit	2
with manual operation	3
with pneumatic operation DN40 - DN100	4
with pneumatic operation and feedback unit DN40 - DN100	5
not used	6-9

### Connection Valve inlet

xxxx xxx x <b>X</b> x-xxx	
Connection	Pos. 8
various connection types according to customer specifications	1 - 9 A - Z

**Connection Valve outlet**

xxxx xxx xx <b>X</b> -xxx	
<b>Connection</b>	<b>Pos. 9</b>
various connection types according to customer specifications	1 - 9 A - Z

**Separator**

xxxx xxx xxx <b>-</b> xxx	
	<b>Pos. 10</b>
KIESELMANN Standard	-
not used	0
customer specifications	1

**Sealing material**

xxxx xxx xxx- <b>X</b> xx	
<b>Sealing material</b>	<b>Pos. 11</b>
EPDM	1
HNBR	2
FKM	3
-	4
EPDM & heating	5
HNBR & heating	6
FKM & heating	7

**Pressure range**

xxxx xxx xxx-x <b>X X</b>							
<b>Pressure range [bar]</b>							
<b>DN 25</b>	<b>DN 40</b>	<b>DN50</b>	<b>DN65</b>	<b>DN80</b>	<b>DN100</b>	<b>Pos. 12</b>	<b>Pos. 13</b>
0.5 - 1.5	0.2 - 1.0	0.3- 0.9	0.4 - 1.5	0.3 - 0.9	0.3 - 1.1	1	0
1.6 - 2.5	1.1 - 3.0	1.0 - 1.7	1.6 - 3.0	1.0 - 1.9	1.2 - 1.8	2	0
2.6 - 4.5	3.1 - 7.0	1.8 - 2.9	3.1 - 7.0	2.0 - 3.3	1.9 - 3.2	3	0
4.6 - 7.0	7.1 - 12.0	3.0 - 6.0	7.1 - 9.0	3.4 - 4.3		4	0
7.1 - 12.0		6.1 - 12.0		4.3 - 8.0		5	0
0.2 - 0.4						6	0



## 11 Appendix

### 11.1 Declaration of incorporation



#### Declaration of incorporation

Translation of the original

#### Manufacturer / authorised representative:

**KIESELMANN GmbH**

Paul-Kieselmann-Str. 4-10

75438 Knittlingen

Germany

#### Authorised representative:

(for compiling technical documents)

**Achim Kauselmann**

(Documentation / Development)

KIESELMANN GmbH

Paul-Kieselmann-Str. 4-10

75438 Knittlingen

Germany

<u>Product name</u>	<u>Function</u>
pneum. Lift actuators	Stroke movement
pneum. Rotary actuators	Rotary movement
Ball valves	Media cutoff
Butterfly valves	Media cutoff
Single seat valves	Media cutoff
Flow control valves	Control of liquefied media
Throttle valve	Control of liquefied media
Overflow valve	Definition of fluid pressure
Double seat valve	Media separation
Bellow valves	Sampling of liquids
Sampling valves	Sampling of liquids
Two way valves	Media cutoff
Tankdome fitting	Prevention of overpressure and vacuum, Tank cleaning
Safety valve	Prevention of overpressure

The manufacturer hereby states that the above product is considered as an incomplete machine in the sense defined in the Directive 2006/42/EC on Machinery. The above product is exclusively intended to be installed into a machine or an incomplete machine. The said product does not yet conform to all the relevant requirements defined in the Directive on Machinery referred to above for this reason.

The specific technical documents listed in Appendix VII, Part B, have been prepared. The Authorized Agent empowered to compile technical documents may submit the relevant documents if such a request has been properly justified.

Commissioning of an incomplete machine must not only be carried out if it has been determined that the respective machine into which the incomplete machine is to be installed conforms to the regulations set out in the Directive on Machinery referred to above.

The above product conforms to the requirements of the directives and harmonized standards specified below:

- Directive 2014/68/EU
- EN ISO 12100 Safety of machinery

Knittlingen, 21.09.2017

i.V. Uwe Heisswolf  
Head of Development

