



# KIESELMANN

FLUID PROCESS GROUP

Translation of the original

Operating instruction

## GEMBRA Aseptic - Tank Outlet Valve

Type: 5850



**KIESELMANN GmbH**

Paul-Kieselmann-Str. 4-10  
D - 75438 Knittlingen

 +49(0) 7043 371-0 •  +49(0) 7043 371-125  
[www.kieselmann.de](http://www.kieselmann.de) • [info@kieselmann.de](mailto:info@kieselmann.de)

---

Copyright: © KIESELMANN FLUID PROCESS GROUP

## Table of contents

<b>1</b>	<b>General informations</b>	<b>4</b>
1.1	Informations for your safety	4
1.2	Marking of security instructions	4
1.3	General designated use	4
1.4	Personnel	4
1.5	Modifications, spare parts, accessories	5
1.6	General instructions	5
<b>2</b>	<b>Safety instructions</b>	<b>6</b>
2.1	Intended use	6
2.2	General notes	6
2.3	General safety instructions	6
<b>3</b>	<b>Specification</b>	<b>8</b>
3.1	Modular system	8
3.2	Valve design	8
<b>4</b>	<b>Function and operation</b>	<b>9</b>
4.1	Description of function	9
4.2	Control system and position indicator	9
4.3	Basic Position of Valve	9
4.4	Pneumatic valve activation	10
<b>5</b>	<b>Commissioning, service and maintenance</b>	<b>11</b>
5.1	Commissioning	11
5.1.1	Installation instructions	11
5.1.2	General welding guidelines	11
5.1.3	ATEX - Guidelines	11
5.2	Cleaning	12
5.3	Service	12
<b>6</b>	<b>Technical data</b>	<b>13</b>
6.1	Torques	13
<b>7</b>	<b>Disassembly and assembly</b>	<b>14</b>
7.1	Disassembly	14
7.1.1	Assembly valve insert VE	15
7.1.2	Replacement wear parts	15
7.2	Assembly	19
7.2.1	Mounting clamp coupling (VK)	19
7.2.2	Mounting diaphragm (D2) and valve insert (VE)	20
<b>8</b>	<b>Drawings and dimensions</b>	<b>23</b>
8.1	Drawings	23
8.2	Dimensions	25
8.3	Control units	26
<b>9</b>	<b>Wearing parts</b>	<b>27</b>
9.1	Wearing parts list	27
<b>10</b>	<b>Classification</b>	<b>29</b>
10.1	Structure of Order Number	29
<b>11</b>	<b>Appendix</b>	<b>30</b>
11.1	Declaration of incorporation	30

# 1 General informations

## 1.1 Informations for your safety

We are pleased that you have decided for a high-class KIESELMANN GmbH product. With correct application and adequate maintenance, our products provide long time and reliable operation.





Before installation and initiation, please carefully read this instruction manual and the security advices contained in it. This guarantees reliable and safe operation of this product and your plant respectively. Please note that an incorrect application of the process components may lead to great material damages and personal injury.

In case of damages caused by non observance of this instruction manual, incorrect initiation, handling or external interference, guarantee and warranty will lapse!

Our products are produced, mounted and tested with high diligence. However, if there is still a reason for complaint, we will naturally try to give you entire satisfaction within the scope of our warranty. We will be at your disposal also after expiration of the warranty. In addition, you will also find all necessary instructions and spare part data for maintenance in this instruction manual. If you don't want to carry out the maintenance by yourself, our KIESELMANN GmbH - service team will naturally be at your disposal.

## 1.2 Marking of security instructions

Hints are available in the chapter "safety instructions" or directly before the respective operation instruction. The hints are highlighted with a danger symbol and a signal word. Texts beside these symbols have to be read and adhered to by all means. Please continue with the text and with the handling at the valve only afterwards.

Symbol	Signal word	Meaning
	DANGER	Imminent danger which will result severe personal injury or death.
	WARNING	Imminent danger which may result severe personal injury or death.
	CAUTION	Dangerous situation which may cause slight personal injury or material damages.
	NOTICE	An harmful situation which may result in damages of the product itself or of adjacent vicinity.
	INFORMATION	Marks application hints and other information which is particularly useful.

## 1.3 General designated use

The fitting is designed exclusively for the purposes described below. Using the fitting for purposes other than those mentioned is considered contrary to its designated use. KIESELMANN GmbH cannot be held liable for any damage resulting from such use. The risk of such misuse lies entirely with the user. The prerequisite for the reliable and safe operation of the fitting is proper transportation and storage as well as competent installation and assembly. Operating the fitting within the limits of its designated use also involves observing the operating, inspection and maintenance instructions.

## 1.4 Personnel

Personnel entrusted with the operation and maintenance of the tank safety system must have the suitable qualification to carry out their tasks. They must be informed about possible dangers and must understand and observe the safety instructions given in the relevant manual. Only allow qualified personnel to make electrical connections.

## **1.5 Modifications, spare parts, accessories**

Unauthorized modifications, additions or conversions which affect the safety of the fitting are not permitted. Safety devices must not be bypassed, removed or made inactive. Only use original spare parts and accessories recommended by the manufacturer.

## **1.6 General instructions**

The user is obliged to operate the fitting only when it is in good working order. In addition to the instructions given in the operating manual, please observe the relevant accident prevention regulations, generally accepted safety regulations, regulations effective in the country of installation, working and safety instructions effective in the user's plant.

## 2 Safety instructions

### 2.1 Intended use

Tank outlet valves are used as manually or pneumatically controlled Shut-off valves in units of the beverage and food industry, the pharmacy, the biotechnology as well as the chemical industry.

### 2.2 General notes



#### NOTICE - observe the operating instructions

To avoid danger and damage, the fitting must be used in accordance with the safety instructions and technical data contained in the operating instructions.



#### NOTICE

All data are in line with the current state of development. Subject to change as a result of technical progress.

### 2.3 General safety instructions



#### ⚠ WARNING

##### Risk of injury by moving parts

Do not grab into the valve when the actuator is pressurized. Limbs can be crushing or amputating.

- Remove the control air line before dismantling.
- Ensure that the actuator is unpressurized.



#### ⚠ WARNING

##### Risk of injury by outflowing medium

Dismantling the valve or valve assemblies from the plant can cause injuries.

- Medias flowing through the leakage drain outlet are to be drained off without splashing into a discharge arrangement.
- Carry the disassembling only if when the plant has been rendered pressure-less and free of liquid and gas.



#### ⚠ WARNING

##### Risk of injury by pre-stressed pressure spring.

The actuator is spring-loaded. When disassembling the actuator, components that jump out may cause injuries.

- For dismantling please observe the separate assembly instructions.
- We recommend having the manufacturer do the maintenance work required for the actuation.



#### ⚠ CAUTION

##### When mounting the clamps, the max. torque must not be exceeded.

(see technical data)



#### ⚠ CAUTION

To avoid air leaking, only use pneumatic connection parts that have an O-ring seal facing the even surface.



**⚠ CAUTION**

**Before starting the system, the entire pipeline system must be thoroughly cleaned.**









**⚠ CAUTION**

**Steps should be taken to ensure that no external forces are exerted on the fitting.**



### 3 Specification

#### 3.1 Modular system

KI-Top control head		feedback unit
		
Stainless steel hood	Transparent hood	Feedback unit with finger guard (E)
Valve insert		
		
PTFE / k-flex   PTFE / EPDM		
Valve housing		
S	S - S	
		

#### 3.2 Valve design

##### GEMBRA Aseptic - Tank Outlet Valve

Angle valve S	T-valve S-S
	



## 4 Function and operation

### 4.1 Description of function

#### Leakage detection

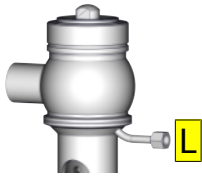

Any leaks occurring due to damaged valve plate seals are drained to the exterior without pressure via the leakage discharge (L).

Valve function:	<ul style="list-style-type: none"> <li>Shut off fluid media in tanks and vessels.</li> </ul>
Actuation:	<ul style="list-style-type: none"> <li>pneumatic operation by a lift drive (air/spring)</li> </ul>
Activation:	<ul style="list-style-type: none"> <li>Pneumatic via 3/2-way solenoid valves (See "Pneumatic Valve Activation")</li> </ul>

#### Description of function - Lift actuator

Normally closed (NC) Basic position: Valve close	
pneum. operated	→ opens the valve
undivided pneum. operated	→ spring force closes the valve

### 4.2 Control system and position indicator



#### Feedback unit -optional-

Optionally, modular valve control head systems can be installed to the actuator for reading and actuating valve positions. The standard version is a closed system with SPS or ASI-bus switch-on electronics, and integrated 3/2-way solenoid valves. For tough operating conditions we recommend employing a high-grade steel cover.



#### Feedback unit with finger guard -optional-

For the acquisition of the valve positions over inductive initiators (Sensors), a feedback unit is mounted on the actuation. The enquiry takes place over the position of the piston rod.

### 4.3 Basic Position of Valve

Actuator type: normal closed (NC)		
	Basic position: Valve closed - spring closed: Line A - B closed	Valve open - air open: Line A - B open
Angle valve		
T-valve		

### 4.4 Pneumatic valve activation

Antriebsart: normal closed (NC)

Valve functions	Pneum. activation via control head with solenoid valves	Pneum. activation via external solenoid valves
valve "OPEN"	Control supply air P - MV1 - P1/LA2	Control supply air ext.MV1 - LA2
valve "CLOSE"	Ventilation P2/LA2 - MV1 - R valve is closing by spring	Ventilation LA2- ext.MV1 valve is closing by spring
	Control head with solenoid valve	external pneum. activation
MV = solenoid valve R = de-aeration, sound absorber P = compressed-air inlet (control unit) LA = air supply S = Slide switch, manual operation of solenoid valve Si = Sensors M12x1 E = mounting kit for feedback unit		

## 5 Commissioning, service and maintenance

### 5.1 Commissioning

#### 5.1.1 Installation instructions

##### Fitting position

The valve must be installed vertically with the actuator at the bottom. Liquid must be able to flow freely from the valve housing and the leakage outlet (L).

#### 5.1.2 General welding guidelines

Sealing elements integrated in weld components must generally be removed prior to welding. To prevent damage, welding should be undertaken by certified personnel (EN ISO 9606-1). Use the TIG (Tungsten Inert Gas) welding process.



##### CAUTION

##### Damage and injuries due to high temperature supply

To avoid a distortion of the components, all welding parts must be welded to stress-relieved. Allow all components to cool before assembling.



##### NOTICE

##### Damage due to impurities

Impurities can cause damage to the seals and seals area. Clean inside areas prior to assembly.

#### 5.1.3 ATEX - Guidelines

For valves or plants/installations that are operated in the ATEX area, sufficient bonding (grounding) must be ensured (see valid ATEX Guidelines EG).

## 5.2 Cleaning

### Cleaning

Ideally, cleaning is carried out with pipe system cleaning when the valve is open.

## 5.3 Service



### RECOMMENDATION

#### Replacement of seals

To achieve optimal maintenance cycles, the following points must be observed!

- When replacement of seals, all product-contacting seals should be replaced.
- Only original spare parts may be installed.

#### Maintenance interval

The maintenance intervals depend on the operating conditions "temperature, temperature-intervals, medium, cleaning medium, pressure and opening frequency". We recommend replacing the seals 1-year cycle. The user, however should establish appropriate maintenance intervals according to the condition of the seals.

#### Lubricant recommendation

	EPDM; HNBR; NBR; FKM; k-flex	- Klüber Paraliq GTE703*
	Silicone	- Klüber Sintheso pro AA2*
	Thread	- Interflon Food*
<p>*) It is only permitted to use approved lubricants, if the respective fitting is used for the production of food or drink. Please observe the relevant safety data sheets of the manufacturers of lubricants.</p>		

## 6 Technical data

Model	Aseptic Single seat-tank outlet valve		
Size	DN40 - DN80 OD 1½" - OD 3"		
Connection type	<ul style="list-style-type: none"> <li>weld-on end DIN EN 10357</li> </ul>		
Operating pressure	DN 40- DN 65	max. 10 bar	
	OD 1½" - OD 2½"	max. 10 bar	
	DN 80 / OD 3"	max. 8 bar	
Cleaning pressure	3 bar		
Pressure resistance	30 bar		
Leakage rate	A (DIN EN 12266-1)		
Control air pressure	5,5 - 8,0 bar		
Quality of control air:	ISO 8573-1 : 2001 quality class 3		
Temperature range	Ambient temperature:	+4°C to +45°C (air)	
	Operating temperature:	+4°C to +95°C (medium dependent)	
	Sterilisation temperature:	k-flex/PTFE +140°C (SIP 30 min)	EPDM/PTFE +140°C (SIP 30 min)
Material (in contact with product)	Stainless steel:	1.4404 / AISI 316L	
	Surface:	Ra < 0,8µm mat finish	
	Sealing material:	<ul style="list-style-type: none"> <li>EPDM (FDA)</li> <li>HNBR (FDA)</li> <li>k-flex (FDA)</li> </ul>	

### 6.1 Torques

	ND	40	50	65	80
	Inch	1½	2	2½	3
<b>Torque</b>					
Clamp coupling		15	15	25	25

## 7 Disassembly and assembly

### 7.1 Disassembly

#### Mounting tools

<b>Tool kit</b> for GEMBRA Aseptic-Single seat valve DN40 - DN80		ST4, ST10, ST20, ST21, ST22, T31, T10	582000010-000
T1		Combination wrench-Set	SW 8 - SW 24 -
ST20		Spanner	SW 30 - 32 8618030032-000
T2		Allen key - Set	1.5 - 10 -
T3		Screwdriver Set	Size 2,5 - 10 PH0,PH1 -
T4		Soft-head hammer	- -
T10		Joint -pin wrench	Pin Ø6 8027000065-000
T31		Round rod	ø8 5620065007-020
T30		Needle	- -
ST4		Centring ring - valve plate seal	DN 40 - 50 5620050025-020 DN65 5620065025-020 DN80 5620080025-020 DN100 5620100025-020 DN125 5620125025-020 DN150 5620150025-020
ST11		Mounting wrench A Mounting wrench B	DN 40 - 65 5836000065-000 DN 80 5836000080-000



#### NOTICE

All threaded joint have right-hand thread.

Dismantle pneumatic and electrical connections. Unscrew fittings for CIP, discharge and feed lines.

### 7.1.1 Assembly valve insert VE

#### - air open- spring close (NC)

#### - air open - air close (DA)

- Remove the hood (H) from control head.
- Connect control air to the air connection (P) and lift the piston (2) by actuating the slide switch (S).
- Unscrew and remove the clamp coupling (VK).
- Remove the completely valve insert (VE) from the housing (VG).
- Disconnect the air supply (P), the valve moves to the basic position.
- To prevent damage to the control head, re-install the hood (H).

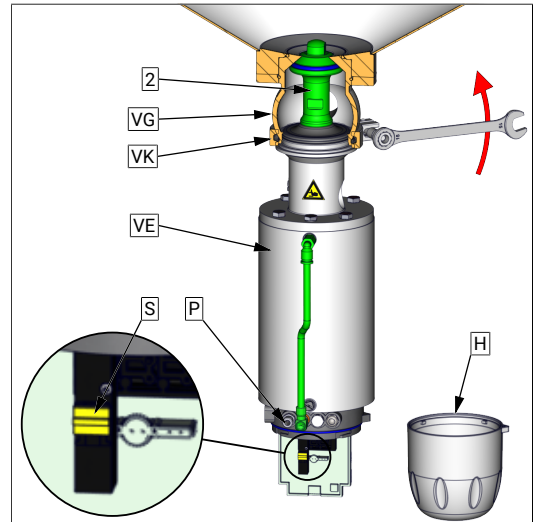

#### - air close- spring open (NO)

- Unscrew and remove the clamp coupling (VK).
- Remove the completely valve insert (VE) from the housing (VG).

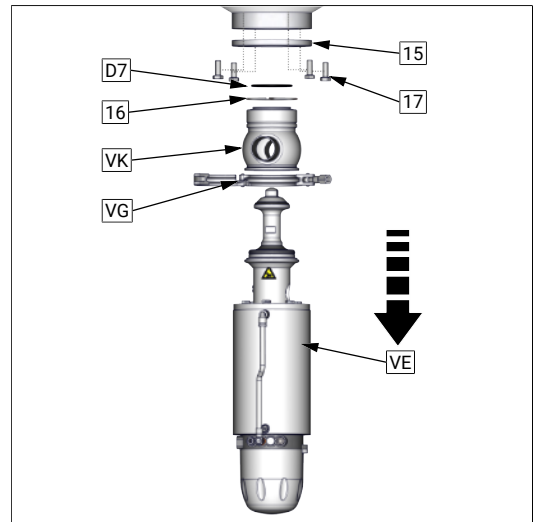

### 7.1.2 Replacement wear parts

- Remove the hood (H) from control head (bayonet lock).
- Unscrew the screws (S1).
- Remove the control head.

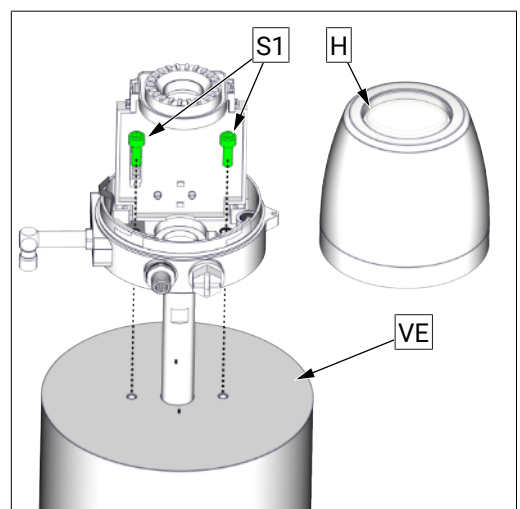

- Unscrew the piston plate (1), hold it against with a fork wrench at the piston (2).
- Remove seal (D1).

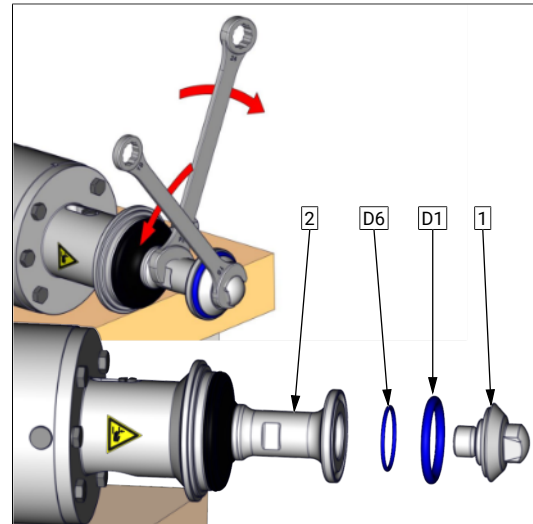

- Unscrew the stud bolt (4).

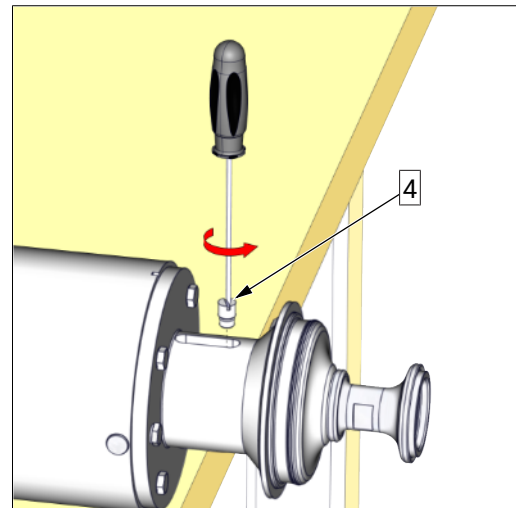

- Turn the piston (2) 180 ° so that the hole (B) is in the slot (L) of the lantern (5).

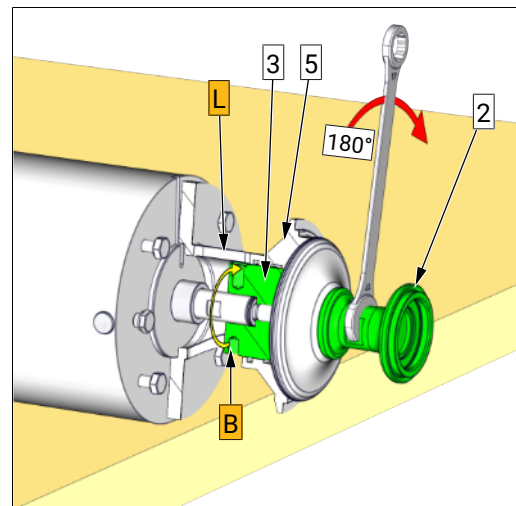



- Insert a round rod  $\varnothing 8$  into the hole (B) and unscrew the piston (2) with a fork wrench from the upper piston (3).

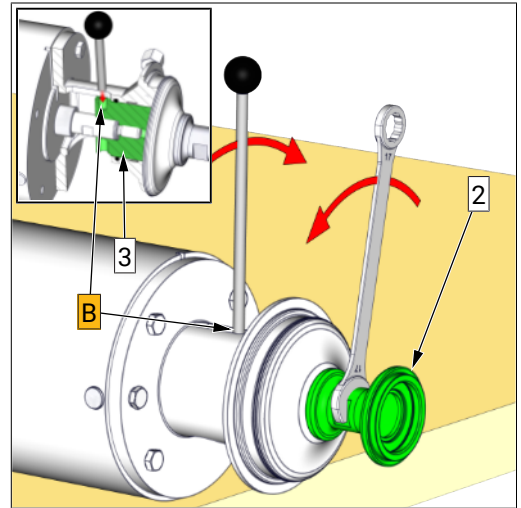

- Dismount the membrane (D2).

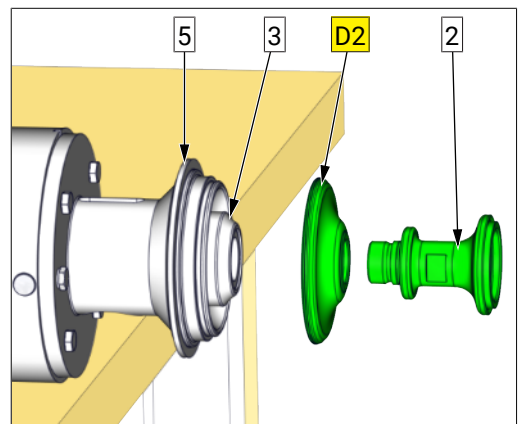

- Unscrew the screws (6).
- Remove lantern (5).

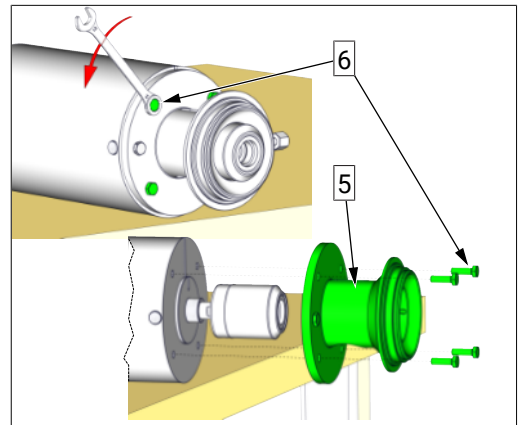

- Unscrew piston (3) from piston rod (7).
- Remove screw locking (D5).

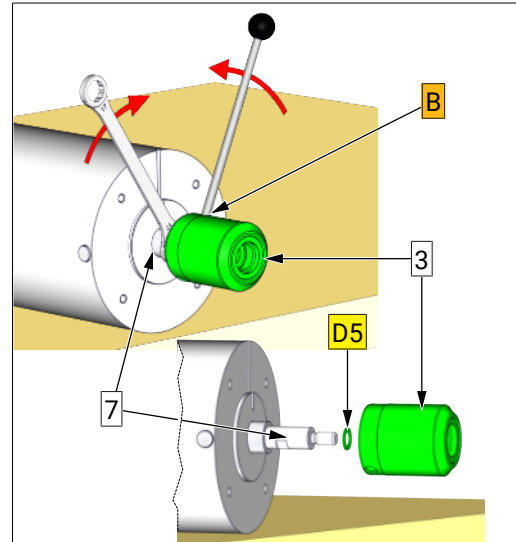

- Pierce the O-ring (D4) with a sharp tool and carefully remove it from the groove.
- Check plain bearing (D3) for wear and replace if necessary.

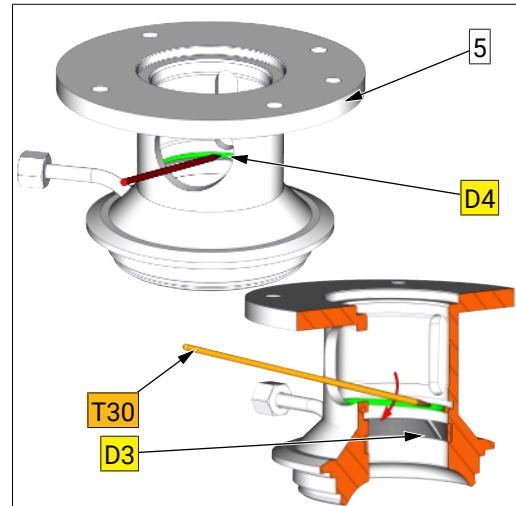

## 7.2 Assembly

- Before installation, thoroughly clean and slightly lubricate mounting areas and running surfaces.
- Assemble in reverse order.



### NOTICE

Alternately press and roll the O-rings into the groove with round body.

#### Performance test

- Check the function according to the specified performance data in the operating state.

### 7.2.1 Mounting clamp coupling (VK)



### NOTICE

**During assembly, the following points must be observed!**

Carefully fit in the complete valve insert into the casing. When fitting the valve insert and running surfaces onto the piston, do not damage.

#### ➤ Mounting clamp coupling

- For mounting the clamp coupling, please note that it continuously fits form locking to the inclinations of the casing and the lantern/casing bottom.
- The centring of the retaining clamp during tightening can be accomplished with a slight beat (please use a soft-head hammer) on the extent of the retaining clamp.
- When tightening the clamp coupling, please pay attention to the turning moment and the gap size 'S' ( $\leq 0,4\text{mm}$ ) between the components.
- Check valve functions by manually activating the 3/2-way solenoid valves after assembly!

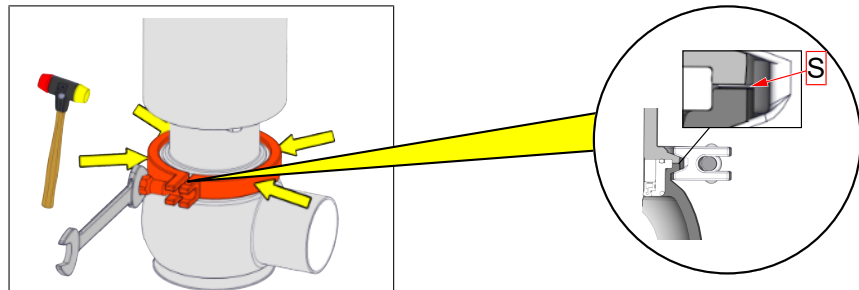

#### Torques

	ND	25	40	50	65	80	100
	Inch	1	1½	2	2½	3	4
<b>Clamp coupling (Nm):</b>		15	15	15	25	25	55

## 7.2.2 Mounting diaphragm (D2) and valve insert (VE)

### 7.2.2.1 Adjusting the mounting position

#### Adjusting the installation position with mounting tool

ST11		Mounting wrench A	DN 40 - 65	5836000065-000
		Mounting wrench B	DN 80	5836000080-000

#### Type of actuator: air open- spring close (NC)

- Unscrew cap (12).
- Connect compressed air to the air supply (LA2). The piston moves toward (X).
- Screw the mounting wrench (ST11) onto the spindle (10) until stop.
- Disconnect the compressed air from the air supply (LA2). The piston moves to the mounting position.

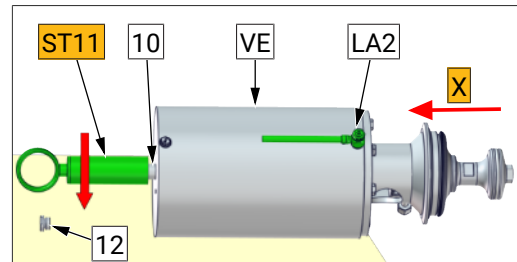

#### Type of actuator: air close - spring open (NO)

- Unscrew cap (12).
- Screw the mounting wrench (ST11) onto the spindle (10) until stop.
- Connect compressed air to the air supply (LA1).
- The piston moves to the mounting position.

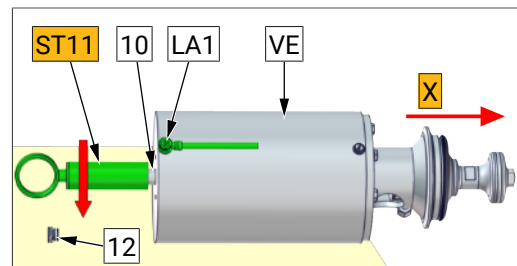

#### Type of actuator: air open - air close (DA)

- Unscrew cap (12).
- Screw the mounting wrench (ST11) onto the spindle (10) until stop.
- Connect compressed air to the air supply (LA2).
- The piston moves to the mounting position.

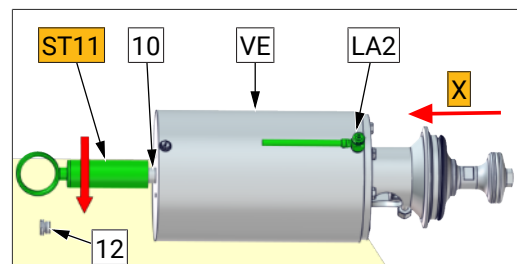

**Adjusting the installation position without mounting tool**

- Unscrew cap (12).
- Connect compressed air at the throttle valve (LA1 NO) or (LA2 NA / NC) Depending on the actuator type the piston moves on or off.
- Disconnect the compressed air (LA1 or LA2).
- The piston remain in the position. Position a calliper on the adjustment dimension M1 or M2.
- Slowly open the throttle valve at so that the piston drives out or in.
- Close the throttle again at the position M1 respectively M2. (If an control head is assembled, the adjustment dimension M1 is measured between the actuator and the pin (4)).

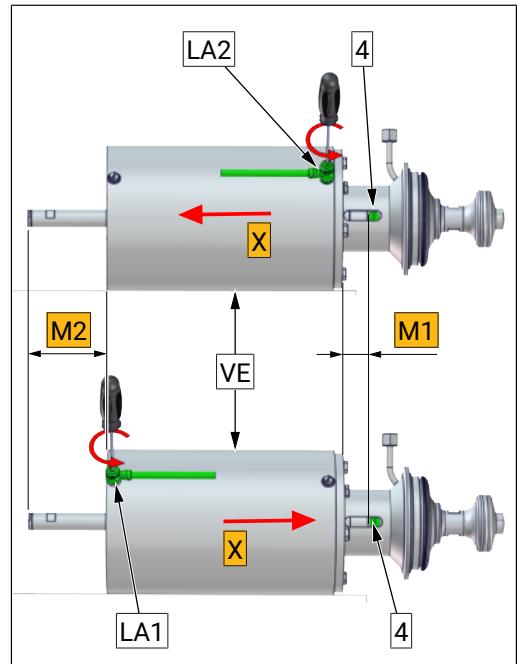

	Bore		Adjustment dimension for mounting position	
	B		M1	M2
DN40		ø7	18.5	107
DN40		ø7	18.5	107
DN50		ø7	18.5	107
DN65		ø8	29	104
DN80		ø8	35	98

**7.2.2.2 Mounting Membrane (D2)**

- Screw the pre-assembled piston (2) onto the piston (3) to the metal stop (MA).  
Slightly grease the threaded connection (G).

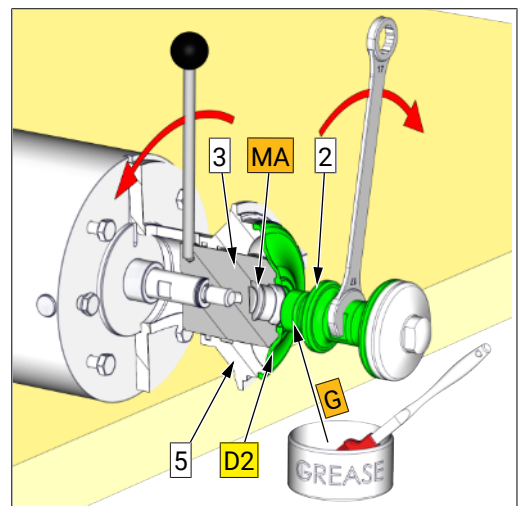

- Adjust the piston to the mounting position. Proceed as described in section "Adjusting the mounting position"

In this valve position the diaphragm (D2) is in its basic position and is optimally compressed between lantern (5) and housing (VG).

- Clip the diaphragm (D2) carefully in the lantern (5).

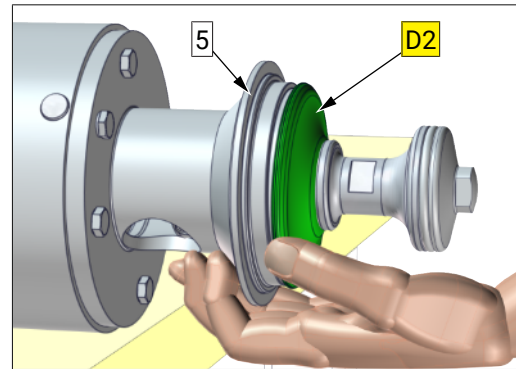

### 7.2.2.3 Mounting the valve insert (VE)

- Adjust the piston to the mounting position. Proceed as described in section „Adjusting the mounting position“.
- Install carefully and without cant the valve insert (VE) into the housing (VG).
- Mount the clamp coupling (VK). Proceed as described in section „Mounting clamp coupling (VK) [▶ 19]“.
- Unscrew the mounting wrench or slowly open the throttle valve (LA2). The piston moves to the basic position.
- Check valve functions.

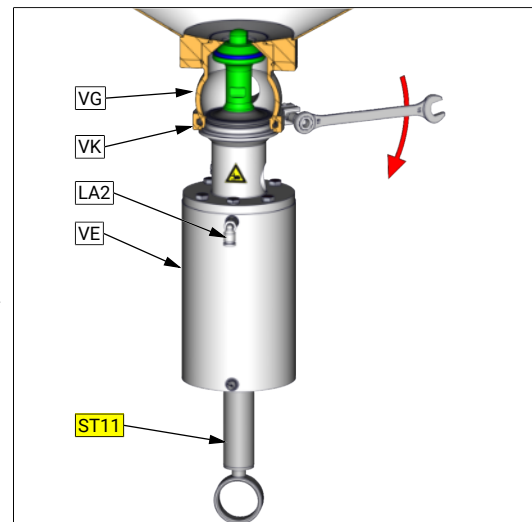

## 8 Drawings and dimensions

### 8.1 Drawings

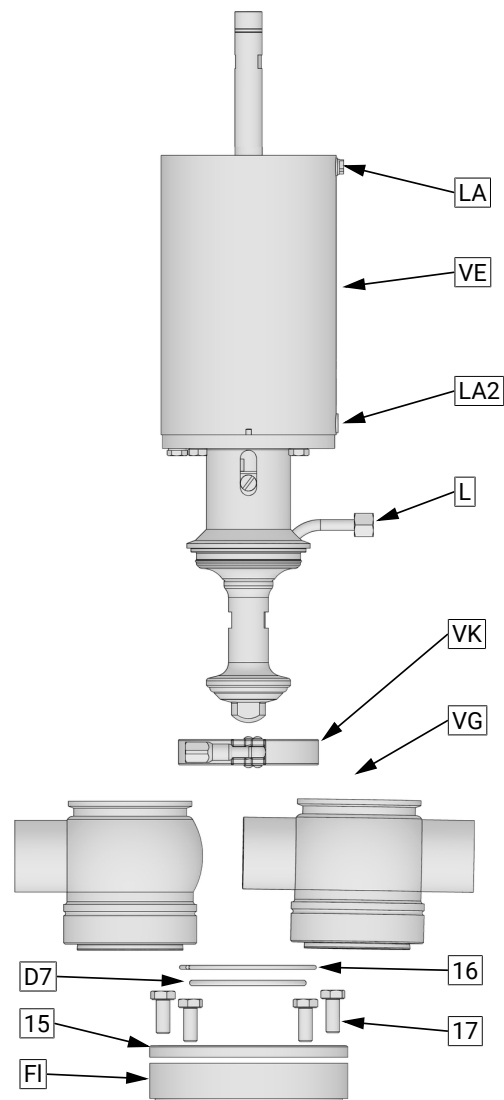

LA	Air connection	VE	Valve insert
LA2	Air connection	L	Leakage drain (G1/4")
VK	Locking clip	VG	Valve housing
16	Retaining ring	D7	O-ring
17	Screw	15	Flange
FI	Flange (not included in seal kit)		

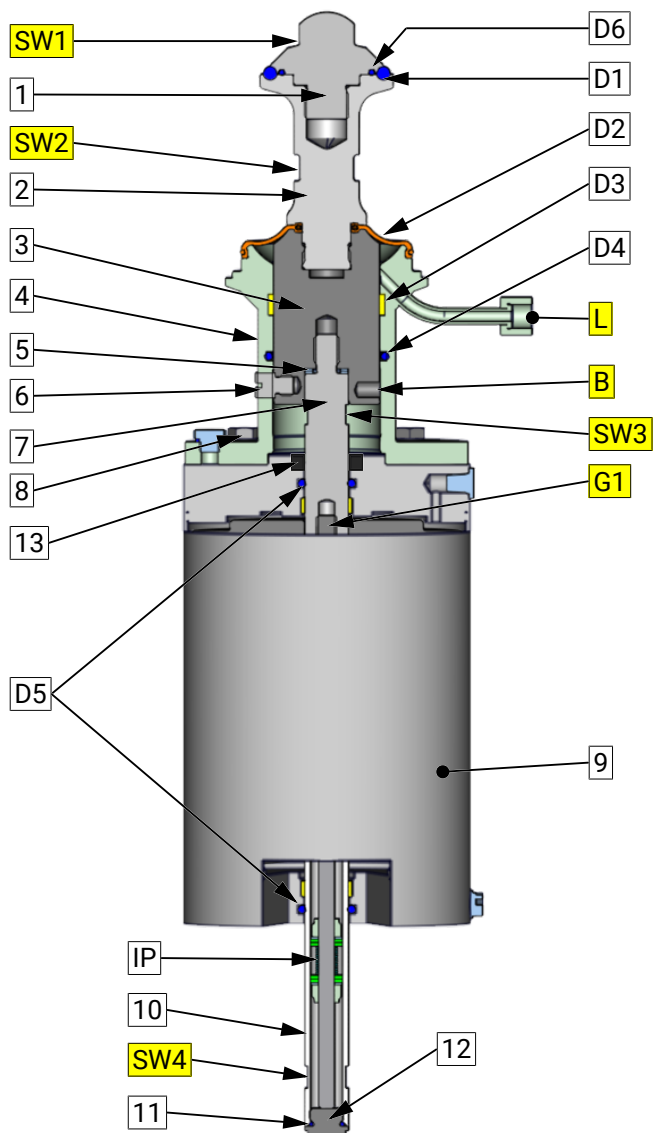

1	Piston plate	2	Piston lower
3	Piston upper	4	Lantern
5	Retaining washer	6	locking screw
7	Piston rod	8	Screw
9	pneum. Linear actuator	10	Spindle
11	O-ring	12	Cap
13	Distance (DN65)	D1	Seal
D2	Membrane	D3	Slide bearing
D4	O-ring	D5	O-ring
D6	Seal	B	Mounting hole
G1	Screw retention detachable (e.g. Loctite 243)	IP	Puls generator (use with control head)
L	Leakage drain G1/4	SW4	Wrench size
SW3	Wrench size	SW1	Wrench size
SW2	Wrench size		

**wrench sizes**

Nominal size	SW1	SW2	SW3	SW4	B
DN 25 / 1"	19	27	17	17	Ø 7
DN 40 / 1½"	19	27	17	17	Ø 7
DN 50 / 2"	19	27	17	17	Ø 7
DN 65 / 2½"	19	24	17	17	Ø 8
DN 80 / 3"	27	30	17	17	Ø 8



## 8.2 Dimensions

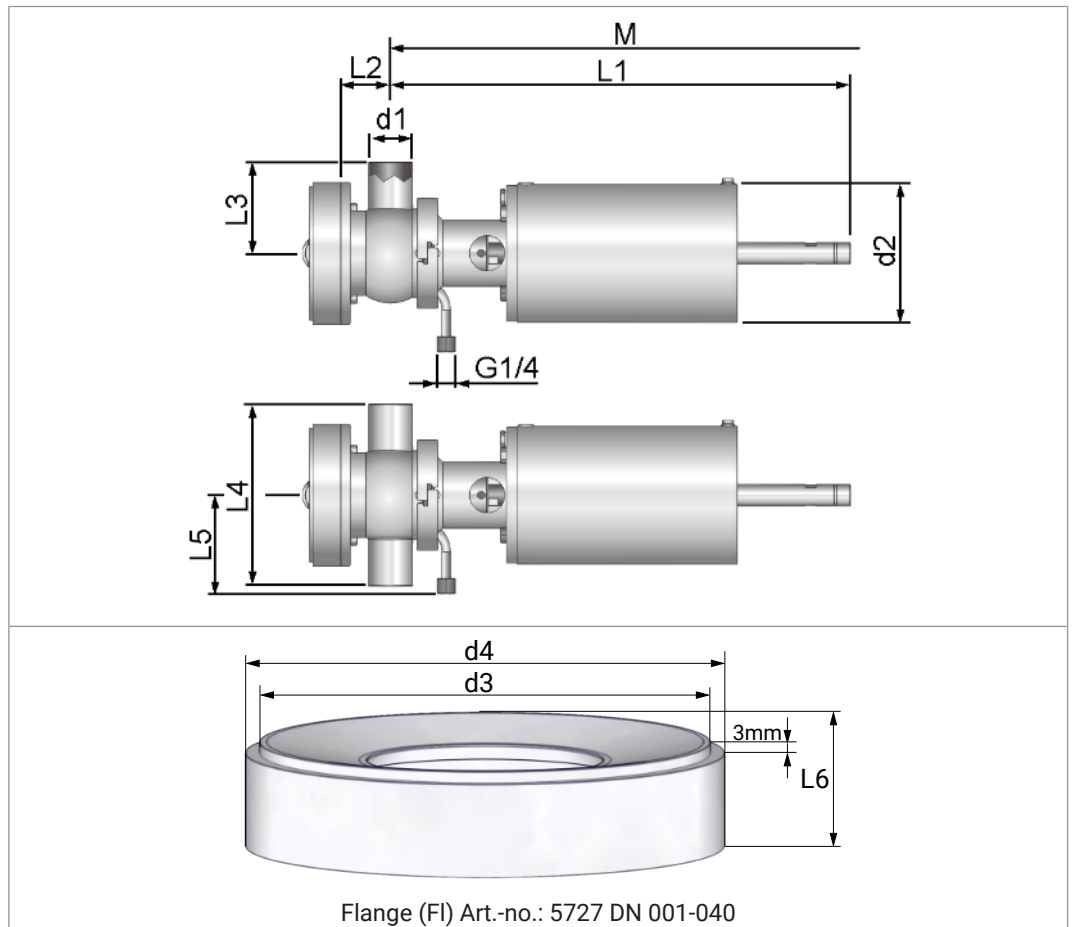

Nominal size	DN 40 1½ Inch	DN 50 2 Inch	DN 65 2½ Inch	DN 80 3 Inch
d1	Ø 41 x 1,5 Ø38,1 x 1,65	Ø 53 x 1,5 Ø50,8 x 1,65	Ø 70 x 2,0 Ø63,5 x 1,65	Ø 85 x 2,0 Ø76,1 x 2,0
d2	Ø 129	Ø 129	Ø 167	Ø 167
d3	Ø 125	Ø 138	Ø 165	Ø 176
d4	Ø 133	Ø 146	Ø 173	Ø 186
L1	430	437	507	536
L2	46.5	45.5	55	74
L3	85	85	110	115
L4	170	170	220	230
L5	92	92	102	107
L6	29	29	29	33
M <sup>1)</sup>	580	590	680	755
Valve stroke	18	18	20	27

Dimensions in mm

1. Installation dimension (M) are incl. control head or sensor mounting

Valves that do not meet the catalogue standards, can lead to dimensional deviations.

### 8.3 Control units

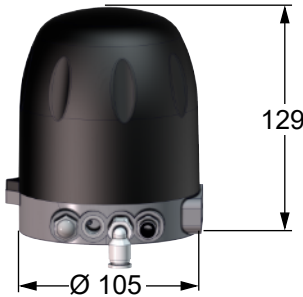
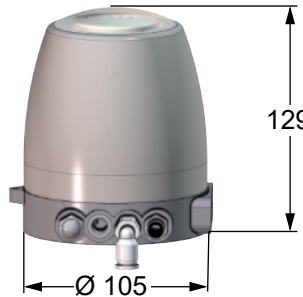
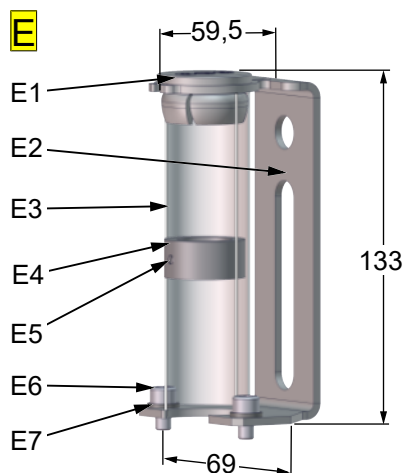
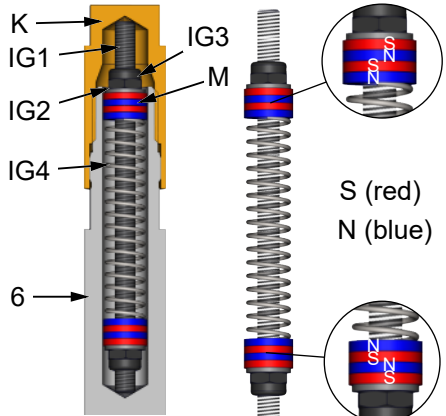
Control head KI-TOP	
with plastic hood - transparent	with stainless steel hood
	
Feedback unit with finger guard (E)	
<ul style="list-style-type: none"> <li>• E1 = Cap</li> <li>• E2 = Angle bracket</li> <li>• E3 = Shell transparent</li> <li>• E4 = Set collar</li> <li>• E5 = Headless pin</li> <li>• E6 = Allen screw</li> <li>• E7 = Flat washer</li> </ul>	
Pulse generator (IG)	
<ul style="list-style-type: none"> <li>• IG1 = Rod</li> <li>• IG2 = Disc</li> <li>• IG3 = Nut</li> <li>• IG4 = Spring</li> <li>• K = Cap</li> <li>• M = Magnet</li> <li>• 6 = Spindle</li> </ul>	

## 9 Wearing parts

### 9.1 Wearing parts list

#### GEMBRA Aseptic - Tank Outlet Valve

Type: 5850

Housing	Seal	Drive	Item number				Wear parts kit	
L-form	k-flex/EPDM	NC	5850 DN 000-xxxx				5850 DN 990-114	
T-form	k-flex/EPDM	NC	5850 DN 200-xxxx				5850 DN 990-114	

Pos	Description	Material	DN 25 1 Inch	DN 40 1½ Inch	DN 50 2 Inch	DN 65 2½ Inch	DN 80 3 Inch	DN 100 4 Inch
VE	Valve insert lö - fs	k-flex	-	5850 040 020-041	5850 050 020-041	5850 065 020-041	5850 080 020-041	-
VG	Housing							
	L-form - DIN	AISI316L	-	5850 040 007-041	5850 050 007-041	5850 065 007-041	5850 080 007-041	-
	L-form - Inch		-	5850 038 007-041	5850 051 007-041	5850 064 007-041	5850 076 007-041	-
	T-form - DIN		-	5850 040 207-041	5850 050 207-041	5850 065 207-041	5850 080 207-041	-
T-form - Inch	-		5850 038 207-041	5850 051 207-041	5850 064 207-041	5850 076 207-041	-	
IP	Pulse generator	-	-	5802 040 005-K000	5802 050 005-K000	5802 065 005-K000	5802 080 005-K000	-
VK	Locking clip	AISI304	-	2122 065 100-020	2122 065 100-020	2122 115 100-020	2122 125 100-020	-
FI	Flange	AISI316L	-	5727 040 001-040	5727 050 001-040	5727 065 001-040	5727 080 001-040	-
15	Flange	AISI316L	-	5727 040 004-041	5727 050 004-041	5727 065 004-041	5727 080 004-041	-
16	Retaining ring	AISI301	-	5727 040 003-031	5727 050 003-031	5727 065 003-031	5727 080 003-031	-
17	Screw (4x)	AISI304	-	8106 010 025-020	8106 010 025-020	8106 012 025-020	8106 012 035-020	-

ND = Nominal diameter e.g. 5850 050 000-041 = DN50

xxxx = Material in product contact / Exterior finish / Control systems

lö = air open; fs = spring close

**Valve insert**

Pos	Description	Material	DN 25 1 Inch	DN 40 1½ Inch	DN 50 2 Inch	DN 65 2½ Inch	DN 80 3 Inch	DN 100 4 Inch
VE	Valve insert lö - fs	k-flex	-	5850 040 020-041	5850 050 020-041	5850 065 020-041	5850 080 020-041	-
1	Piston plate	AISI316L	-	5850 050 025-040	5850 050 025-040	5850 065 025-040	5850 080 025-040	-
2	Piston	AISI316L	-	5850 040 005-040	5850 050 005-040	5850 065 005-040	5850 080 005-040	-
3	Piston	AISI316L	-	5836 040 007-041	5836 040 007-041	5836 065 007-041	5836 080 007-041	-
4	Lantern	AISI304	-	5821 050 014-021	5821 050 014-021	5821 065 014-021	5821 080 014-021	-
5	Screw locking	AISI316L	-	8135 012 195-040	8135 012 195-040	8135 012 195-040	8135 012 195-040	-
6	locking screw	AISI304	-	5836 040 008-020	5836 040 008-020	5836 040 008-020	5836 080 008-020	-
7	Piston rod	AISI303	-	5836 040 006-220	5836 040 006-220	5836 080 006-220	5836 080 006-220	-
8	Screw (4x)	AISI304	-	8106 008 020-020	8106 008 020-020	8106 008 020-020	8106 008 020-020	-
9	Actuator lö - fs	AISI304	-	5200 129 151-032	5200 129 151-032	5200 167 151-032	5200 167 151-032	-
10	Spindle	AISI303	-	5622 100 070-220	5622 100 070-220	5622 100 070-220	5622 100 070-220	-
11	O-ring	EPDM	-	2304 012 020-170	2304 012 020-170	2304 012 020-170	2304 012 020-170	-
12	Cap	AISI303	-	5622 100 071-220	5622 100 071-220	5622 100 071-220	5622 100 071-220	-
13	Distance (DN65)	AISI304	-	-	-	5836 065 010-020	-	-

**Wear parts set k-flex/EPDM**

Pos	Description	Material	DN 25 1 Inch	DN 40 1½ Inch	DN 50 2 Inch	DN 65 2½ Inch	DN 80 3 Inch	DN 100 4 Inch
	Seal kit	k-flex/ EPDM	-	5850 040 990-114	5850 050 990-114	5850 065 990-114	5850 080 990-114	-
D1	O-ring	k-flex	-	2304 045 060-114	2304 045 060-114	2304 060 060-114	2304 079 060-114	-
D2	Membrane	PTFE	-	5820 050 020-194	5820 050 020-194	5820 065 020-194	5820 080 020-194	-
D3	Piston seal	KV	-	8051 250 010-081	8051 250 010-081	8051 190 010-081	8051 220 020-081	-
D4	O-ring	EPDM	-	2304 049 035-170	2304 049 035-170	2304 062 035-159	2304 072 035-170	-
D5	O-ring (2x)	EPDM	-	2304 019 035-171	2304 019 035-171	2304 019 035-171	2304 019 035-171	-
D6	Seal	PTFE	-	2304 038 026-159	2304 038 026-159	2352 059 052-053	2352 078 071-053	-
D7	O-ring	EPDM	-	2304 062 035-159	2304 075 040-054	2304 090 040-170	2304 102 050-159	-

## 10 Classification

### 10.1 Structure of Order Number

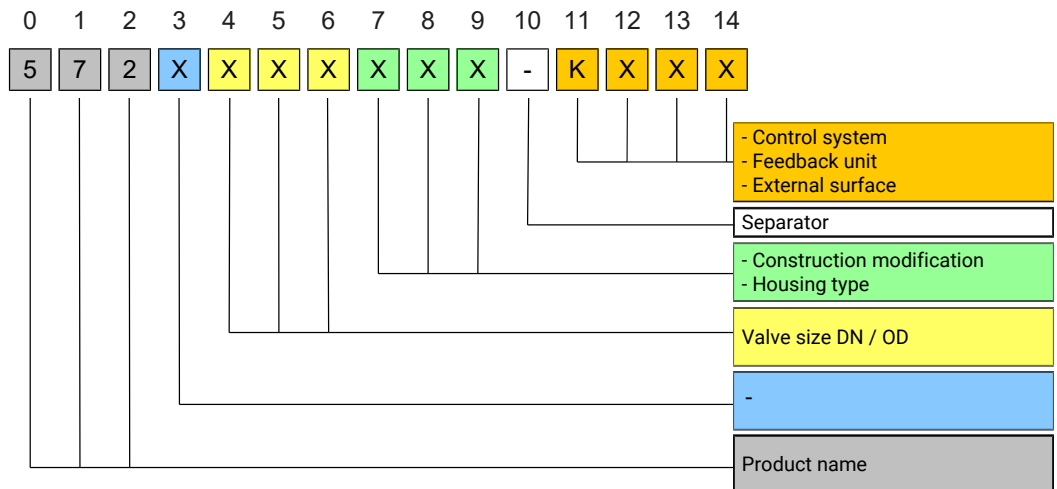

Product name	0	1	2	3
Type: 5850 GEMBRA Aseptic-Tank Outlet Valve	5	8	5	0

Valve size DN / OD								
DN	4	5	6	OD	4	5	6	
DN 25	0	2	5	OD 1 "	0	2	6	
DN 40	0	4	0	OD 1 1/2"	0	3	8	
DN 50	0	5	0	OD 2 "	0	5	1	
DN 65	0	6	5	OD 2 1/2"	0	6	4	
DN 80	0	8	0	OD 3 "	0	7	6	

Design modification & Housing type				
Type	Housing	7	8	9
5850 xxx 000-xxxx	L-form S-S	0	0	0
5850 xxx 200-xxxx	T-form SS-S	2	0	0
5850 xxx 020-xxxx (Valve insert)	-	0	2	0

Separator	10
KIESELMANN	-

Control system and position indicator	11	12	13	14
Control head SPS (old version)	5	x	x	-
Control head ASi-Bus (old version)	6	x	x	-
Control head KI-Top SPS	K	5	x	x
Control head KI-Top ASi-Bus	K	6	x	x

Feedback unit	11	12	13	14
Feedback unit with finger guard (5630 005 025-000)	7	5	0	-

External surface	11	12	13	14
Valve without control system, External surface, AISI304, E-polished	0	2	1	-
Valve without control system, External surface, AISI316L, E-polished	0	4	1	-

# 11 Appendix

## 11.1 Declaration of incorporation



**Declaration of incorporation**

Translation of the original

<b>Manufacturer / authorised representative:</b>	<b>KIESELMANN GmbH</b> Paul-Kieselmann-Str. 4-10 75438 Knittlingen Germany
<b>Authorised representative:</b> (for compiling technical documents)	<b>Achim Kauselmann</b> (Documentation / Development) KIESELMANN GmbH Paul-Kieselmann-Str. 4-10 75438 Knittlingen Germany

<u>Product name</u>	<u>Function</u>
pneum. Lift actuators	Stroke movement
pneum. Rotary actuators	Rotary movement
Ball valves	Media cutoff
Butterfly valves	Media cutoff
Single seat valves	Media cutoff
Flow control valves	Control of liquefied media
Throttle valve	Control of liquefied media
Overflow valve	Definition of fluid pressure
Double seat valve	Media separation
Bellow valves	Sampling of liquids
Sampling valves	Sampling of liquids
Two way valves	Media cutoff
Tankdome fitting	Prevention of overpressure and vacuum, Tank cleaning
Safety valve	Prevention of overpressure

The manufacturer hereby states that the above product is considered as an incomplete machine in the sense defined in the Directive 2006/42/EC on Machinery. The above product is exclusively intended to be installed into a machine or an incomplete machine. The said product does not yet conform to all the relevant requirements defined in the Directive on Machinery referred to above for this reason.

The specific technical documents listed in Appendix VII, Part B, have been prepared. The Authorized Agent empowered to compile technical documents may submit the relevant documents if such a request has been properly justified.

Commissioning of an incomplete machine must not only be carried out if it has been determined that the respective machine into which the incomplete machine is to be installed conforms to the regulations set out in the Directive on Machinery referred to above.

The above product conforms to the requirements of the directives and harmonized standards specified below:

- Directive 2014/68/EU
- DIN EN ISO 12100 Safety of machinery

Knittlingen, 21.09.2017

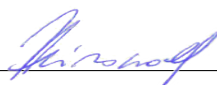
  
i.V. Uwe Heisswolf  
Head of Development

