



KIESELMANN

FLUID PROCESS GROUP

Translation of the original

Operating instruction

Single Stage Control Valves

Type 51xx

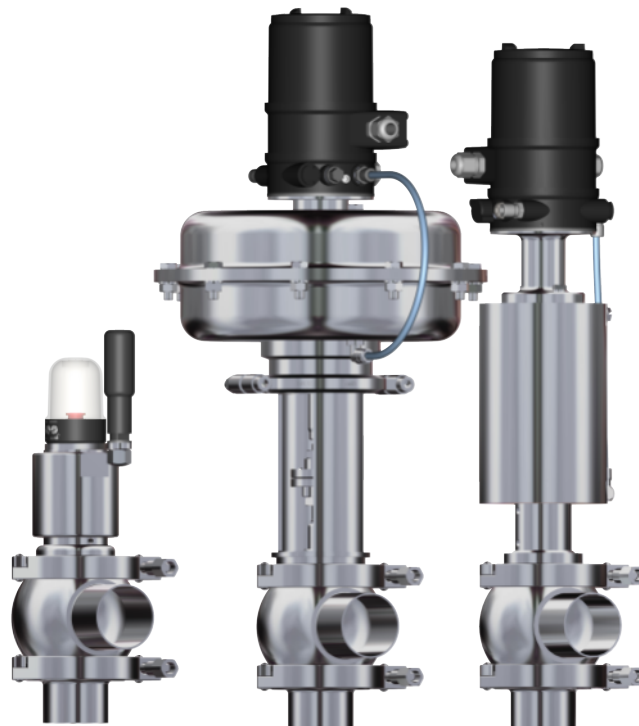

KIESELMANN GmbH

Paul-Kieselmann-Str. 4-10
D - 75438 Knittlingen

 +49(0) 7043 371-0 •  +49(0) 7043 371-125
www.kieselmann.de • info@kieselmann.de

Copyright: © KIESELMANN FLUID PROCESS GROUP

Table of contents

1	General informations	4
1.1	Informations for your safety	4
1.2	Marking of security instructions	4
1.3	General designated use	4
1.4	Personnel	4
1.5	Modifications, spare parts, accessories	5
1.6	General instructions	5
2	Safety instructions	6
2.1	Intended use	6
2.2	General notes	6
2.3	General safety instructions	6
3	Delivery, transport and storage	8
3.1	Delivery	8
3.2	Transport	8
3.3	Storage	8
4	Specification	9
4.1	Valve types	9
5	Function and operation	10
5.1	Description of function	10
5.2	Valve basic position:	11
6	Commissioning, service and maintenance	12
6.1	Commissioning	12
6.1.1	Installation instructions	12
6.1.2	General welding guidelines	12
6.1.3	ATEX - Guidelines	12
6.2	Service	12
6.3	Cleaning	13
7	Technical data	14
7.1	Control valve Type 51xx	14
7.2	Identification	14
7.3	Torques	14
7.4	KV - value	15
8	Disassembly and assembly	16
8.1	Disassembly	16
8.1.1	Removing wearing parts - Valve with manual actuator	17
8.1.2	Removing wearing parts - Valve with piston actuator	19
8.1.3	Removing wearing parts - Valve with diaphragm actuator	22
8.1.4	Removing Interchangeable seat	24
8.2	Assembly	25
9	Mounting kit for positioner	26
9.1	Bürkert positioner Type 8692, 8694	26
10	Drawings and dimensions	28
10.1	Drawings	28
10.2	Dimensions	31
11	Wearing parts	33
11.1	Overview - Seal and wearing parts kits	33
12	Classification	38
12.1	Structure of Order Number	38
13	Appendix	41
13.1	Declaration of incorporation	41

1 General informations

1.1 Informations for your safety

We are pleased that you have decided for a high-class KIESELMANN GmbH product. With correct application and adequate maintenance, our products provide long time and reliable operation.





Before installation and initiation, please carefully read this instruction manual and the security advices contained in it. This guarantees reliable and safe operation of this product and your plant respectively. Please note that an incorrect application of the process components may lead to great material damages and personal injury.

In case of damages caused by non observance of this instruction manual, incorrect initiation, handling or external interference, guarantee and warranty will lapse!

Our products are produced, mounted and tested with high diligence. However, if there is still a reason for complaint, we will naturally try to give you entire satisfaction within the scope of our warranty. We will be at your disposal also after expiration of the warranty. In addition, you will also find all necessary instructions and spare part data for maintenance in this instruction manual. If you don't want to carry out the maintenance by yourself, our KIESELMANN GmbH - service team will naturally be at your disposal.

1.2 Marking of security instructions

Hints are available in the chapter "safety instructions" or directly before the respective operation instruction. The hints are highlighted with a danger symbol and a signal word. Texts beside these symbols have to be read and adhered to by all means. Please continue with the text and with the handling at the valve only afterwards.

Symbol	Signal word	Meaning
	DANGER	Imminent danger which will result severe personal injury or death.
	WARNING	Imminent danger which may result severe personal injury or death.
	CAUTION	Dangerous situation which may cause slight personal injury or material damages.
	NOTICE	An harmful situation which may result in damages of the product itself or of adjacent vicinity.
	INFORMATION	Marks application hints and other information which is particularly useful.

1.3 General designated use

The fitting is designed exclusively for the purposes described below. Using the fitting for purposes other than those mentioned is considered contrary to its designated use. KIESELMANN GmbH cannot be held liable for any damage resulting from such use. The risk of such misuse lies entirely with the user. The prerequisite for the reliable and safe operation of the fitting is proper transportation and storage as well as competent installation and assembly. Operating the fitting within the limits of its designated use also involves observing the operating, inspection and maintenance instructions.

1.4 Personnel

Personnel entrusted with the operation and maintenance of the tank safety system must have the suitable qualification to carry out their tasks. They must be informed about possible dangers and must understand and observe the safety instructions given in the relevant manual. Only allow qualified personnel to make electrical connections.

1.5 Modifications, spare parts, accessories

Unauthorized modifications, additions or conversions which affect the safety of the fitting are not permitted. Safety devices must not be bypassed, removed or made inactive. Only use original spare parts and accessories recommended by the manufacturer.

1.6 General instructions

The user is obliged to operate the fitting only when it is in good working order. In addition to the instructions given in the operating manual, please observe the relevant accident prevention regulations, generally accepted safety regulations, regulations effective in the country of installation, working and safety instructions effective in the user's plant.

2 Safety instructions

2.1 Intended use

The control valve is used for the regulation of media in the food and beverage industry, in pharmaceutical and chemical engineering, as well as in bio-engineering.

2.2 General notes



NOTICE - observe the operating instructions

To avoid danger and damage, the fitting must be used in accordance with the safety instructions and technical data contained in the operating instructions.



NOTICE

All data are in line with the current state of development. Subject to change as a result of technical progress.

2.3 General safety instructions



⚠ WARNING

Risk of injury by moving parts

Do not grab into the valve when the actuator is pressurized. Limbs can be crushing or amputating.

- Remove the control air line before dismantling.
- Ensure that the actuator is unpressurized.



⚠ WARNING

Risk of injury by outflowing medium

Dismantling the valve or valve assemblies from the plant can cause injuries.

- Medias flowing through the leakage drain outlet are to be drained off without splashing into a discharge arrangement.
- Carry the disassembling only if when the plant has been rendered pressure-less and free of liquid and gas.



⚠ WARNING

Risk of injury by moving parts

When dismantle the clamp coupling, the spring preloaded valve insert (air open - spring close) may incur serious injuries by jumping out of the housing.

- First pneumatically open the valve before disassembling the clamp coupling, so that up-stroke the piston.
- Dismount the valve insert.
- Remove the control air line at valve insert.

⇒ Ensure that the actuator is unpressurized.



⚠ WARNING

ATEX - Guidelines

If the valve or the plant is operated in a potentially explosive atmosphere, the valid ATEX directive of the EC and the installation instructions in this operating manual must be observed.

**⚠ CAUTION**

When mounting the clamps, the max. torque must not be exceeded.
(see technical data)

**⚠ CAUTION**

To avoid air leaking, only use pneumatic connection parts that have an O-ring seal facing the even surface.

**⚠ CAUTION**

Before starting the system, the entire pipeline system must be thoroughly cleaned.

**⚠ CAUTION**

Steps should be taken to ensure that no external forces are exerted on the fitting.

3 Delivery, transport and storage

3.1 Delivery

- Immediately after receipt check the delivery for completeness and transport damages.
- Remove the packaging from the product.
- Retain packaging material, or expose of according to local regulations.

3.2 Transport



CAUTION

Risk of injury and damage to the product

During the transport the generally acknowledged rules of technology, the national accident prevention regulations and company internal work and safety regulations must be observed.

3.3 Storage



NOTICE

Damage to the product due to improper storage!

Observe storage instructions
avoid a prolonged storage



INFORMATION

Recommendation for longer storage

We recommend regularly checking the product and the prevailing storage conditions during long storage times.

- To avoid damage to seals and bearings,
 - products up to DN 125 / OD 5 inch should be stored horizontally for maximum 6 months.
 - products larger than DN 125 / 5 inch, should be stored in the upright position with the actuator on top.
- Don't store any objects on the products.
- Protect the products for wetness, dust and dirt.
- The product should be stored in a dry and well ventilated room at a constant temperature (optimal indoor temperature: 25 C ±5 ; indoor humidity data 70% ±5%).
- Protect seals, bearings and plastic parts for UV light and ozone.

4 Specification

4.1 Valve types

Kind of actuator	positioner	Housing type	Sealing material ¹	Nominal diameter	KV - value
Manual operation	A -	- Angle (S-S) - T (SS-S) - Inclined (S-S)	- EPDM - HNBR - FKM - metallic	DN25 - DN125 OD 1 Inch - OD 5 Inch	0.4 m³/h - 160 m³/h
- pneum. Linear actuator	B - GUTH DigiPos C - Bürkert 869x	- Angle (S-S) - T (SS-S) - Inclined (S-S)	- EPDM - HNBR - FKM - metallic		
- pneum. Diaphragm actuator	D - Bürkert 879x E - Samson 3725 F - GUTH DigiPos G - Bürkert 869x	- Angle (S-S) - T (SS-S) - Inclined (S-S)	- EPDM - HNBR - FKM - metallic		

1. Control valve with elastomeric or metallic sealing at the flow cone

Control valve with

Manual operation

Piston Actuator

Diaphragm Actuator

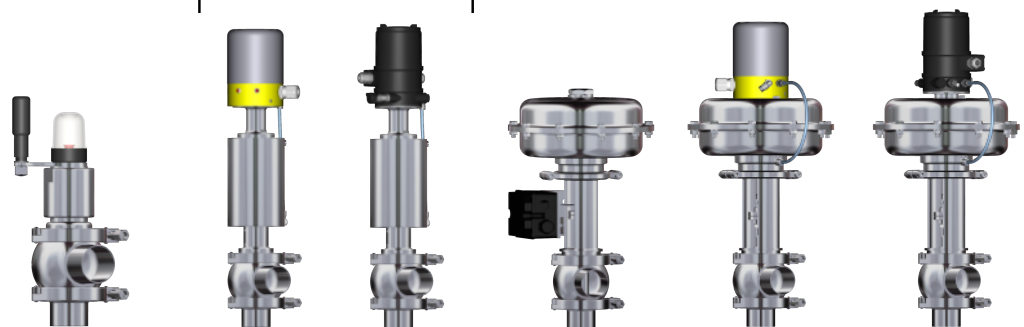

Housing form

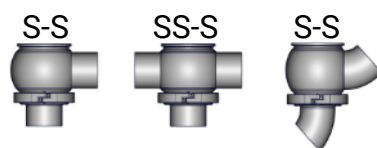

5 Function and operation

5.1 Description of function

The control valve is based on the KIESELMANN AI DS technology. Media with a KVS -values 0, 4 m³/h to 160 m³/h can be regulated through the interchangeable seat concept.

Control via Bürkert Positioner

The valve is operated by means of a digital electro-pneumatic positioner. The positioner forms a closed circuit loop together with the lift actuator and the valve. The lift position defines the actual value which is recorded by a potentiometer. A proportional position is controlled with the specified target value (4-20mA). During the regulating process, the target value is constantly compared to the actual value; any regulating deviations are corrected. The micro-controller regulator allows an automatic zero and lift alignment and automatic commissioning.

Description of function - Control valve

Valve function:	<ul style="list-style-type: none"> Regulation of media in pipelines.
Operation:	<ul style="list-style-type: none"> pneumatic operation by a lift drive (air/spring or air/air) manual operation by a crank-handle (open ☺ / close ☻)
Activation:	<ul style="list-style-type: none"> pneumatically via solenoid valves (positioner) (see "Control via Bürkert positioner")

Description of function - Lift actuator

Normally closed (NC) Basic position: Valve close	
pneum. operated	→ opens the valve
<u>undivided</u> pneum. operated	→ spring force closes the valve

normal open (NO) Basic position: Valve open	
pneum. operated	→ valve "CLOSE"
<u>undivided</u> pneum. operated	→ spring force opens the valve

double acting (DA) Basic position: not defined ¹	
pneum. operated	→ opens the valve
<u>undivided</u> pneum. operated	→ valve "CLOSE"

5.2 Valve basic position:

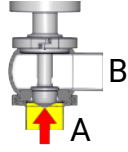
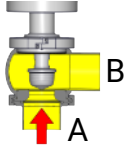
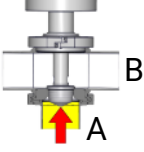
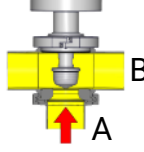
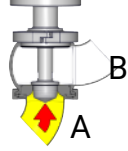
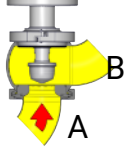
Basic position: Kind of actuation:	Valve closed Normally closed (NC)	Valve open Normally open (NO)
Type: 511x S-S Angle valve	 <p>Line A - B closed</p>	 <p>Line A - B open</p>
Type: 512x SS-S T-valve	 <p>Line A - B closed</p>	 <p>Line A - B open</p>
Type: 513x S-S Inclined seat valve	 <p>Line A - B closed</p>	 <p>Line A - B open</p>

6 Commissioning, service and maintenance

6.1 Commissioning

6.1.1 Installation instructions

Fitting position

Any installation position is possible, however preferably it should be installed vertically. Non-vertical installation means that the outflow pipes must be arranged to allow the liquids to run freely out of the housing.

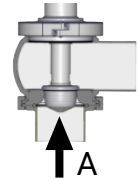

NOTICE

The flow direction is generally in the direction A.

If installed horizontally, some minor residual liquids will remain in the housing.

6.1.2 General welding guidelines

Sealing elements integrated in weld components must generally be removed prior to welding. To prevent damage, welding should be undertaken by certified personnel (EN ISO 9606-1). Use the TIG (Tungsten Inert Gas) welding process.



CAUTION

Damage and injuries due to high temperature supply

To avoid a distortion of the components, all welding parts must be welded to stress-relieved.

Allow all components to cool before assembling.



NOTICE

Damage due to impurities

Impurities can cause damage to the seals and seals area.

Clean inside areas prior to assembly.

6.1.3 ATEX - Guidelines

For valves or plants/installations that are operated in the ATEX area, sufficient bonding (grounding) must be ensured (see valid ATEX Guidelines EG).

6.2 Service



RECOMMENDATION

Replacement of seals

To achieve optimal maintenance cycles, the following points must be observed!

- When replacement of seals, all product-contacting seals should be replaced.
- Only original spare parts may be installed.

Maintenance interval

The maintenance intervals depend on the operating conditions "temperature, temperature-intervals, medium, cleaning medium, pressure and opening frequency". We recommend replacing the seals 1-year cycle. The user, however should establish appropriate maintenance intervals according to the condition of the seals.

Lubricant recommendation

	EPDM; HNBR; NBR; FKM; k-flex	- Klüber Paraliq GTE703*
	Silicone	- Klüber Sintheso pro AA2*
	Thread	- Interflon Food*
*) It is only permitted to use approved lubricants, if the respective fitting is used for the production of food or drink. Please observe the relevant safety data sheets of the manufacturers of lubricants.		

6.3 Cleaning**Cleaning**

Ideally, cleaning is carried out with pipe system cleaning when the valve is open.

7 Technical data

7.1 Control valve Type 51xx

Model:	Control valve with <ul style="list-style-type: none"> • elastomer sealing at the regulation cone (Elastomer) • metallic sealing at the regulation cone (metallic/Elastomer) 	
Valve size:	DN20 - DN125 OD 1 Inch - OD 5 Inch	
Connections:	Weld-on end DIN EN 10357	
Temperature range:	Ambient temperature:	+4 to +45°C (air)
	Operating temperature:	+0 to +95°C (medium dependent)
	Sterilization temperature:	HNBR +120°C (SIP 30 min) EPDM/PTFE +140°C (SIP 30 min) FKM +110°C (SIP 30 min)
Pressure nominal (PN):	16 bar	
Leak rate:	A (DIN EN 12266-1)	
Control air:	<u>Control air pressure:</u> 5,5 - 8,0 bar	<u>Quality of control air:</u> ISO 8573-1 : 2001 quality class 3
Materials: (in product contact)	Stainless steel: Surfaces:	1.4404 / AISI 316 L Ra ≤ 0,8µm - metallic bright; e-polished
	Sealing material:	k-flex (FDA) EPDM (FDA) PTFE (FDA) FKM (FDA)

7.2 Identification

Manufacturer Logo		CE 0036 EN ISO 4126-1	Standards
Order number	KIESELMANN FLUID PROCESS GROUP	ERC	Date
Item number	Order No.: xxxxxxxx / x	MM/JJJJ	Material
Nominal width	Serial No.: xxxxxxxxxxx-xxxx	AISI xxxx	Operating temperature
Pressure nominal	DN xxx	Ts -xx°C/+xxx°C	Discharge coefficient
	PN xx	Kvs xxx	
	Made in the EU		

7.3 Torques

DN	25	40	50	65	80	100	125	150
Inch	1	1½	2	2½	3	4	5	6
Clamp coupling (Nm):	15	15	15	25	25	55	65	65



7.4 KV - value

Pneumatic actuator:					Linear actuator				Diaphragm actuator				
Type (size):					H104	H129	H167	H230	M02	M2	M4	M10	
Control air pressure [bar]:					5.5	5.5	5.5	5.5	4	3	3	3	
K _{VS} -value [m ³ /h]	DN	OD	Seat-Ø [mm]	Stroke [mm]	Adm. Operating pressures [bar]								
					0.2	20	-	5	16				
0.4	25	1"	6	20	16				16				
1.0	25	1"			16				16				
1.6	25	1"	12	20	16				16				
2.5	25	1"			16				16				
4	25	1"			16				16				
	40	1½"			16				16	16			
7	25	1"	22	20	16				10	16			
	40	1½"			16				10	16			
10	25	1"	22	20	16	16			10	16			
	40	1½"			16	16			10	16			
	50	2"			16	16			10	16			
18	40	1½"	34	20	10	16				16			
	50	2"			10	16				16			
	65	2½"			10	16				16			
26	50	2"	46	20		10	16			16			
	65	2½"				10	16			16			
	80	3"				10	16			16			
40	50	2"	46	27			16				16		
	65	2½"						16				16	
	80	3"						16				16	
	100	4"						16				16	
52	65	2½"	60	27			12	16			11	16	
	80	3"						12	16			11	16
	100	4"						12	16			11	16
68	65	2½"	60	27			12	16			11	16	
	80	3"						12	16			11	16
	100	4"						12	16			11	16
85	80	3"	72	27			8	14			8	14	
	100	4"						8	14			8	14
	125	---						8	14			8	14
100	80	3"	81	27			8	14			8	14	
	100	4"						8	14			8	14
	125	---						8	14			8	14
120	100	4"	95	27			5.5	6			6	9	
	125	---						5.5	6			6	9
160	125	5"	120	27				4				8	

8 Disassembly and assembly

8.1 Disassembly

Mounting tools

T1		Combination wrench-Set	SW 8 - SW 24	-
T2		Allen key - Set	1.5 - 10	-
T10		Joint -pin wrench	Pin Ø6	8027000065-000
T11		Hinged hook wrench	-	8027000065-000
T12		Joint face wrench	Pin Ø6 40-80 MM	8028340080-000
T31		Round rod	Ø 5 mm	-
T35		Pin punch	Ø 5 mm	-



NOTICE

All threaded joint have right-hand thread.

Unscrew and remove control air, steam resp. cleaning lines and electrical lines, complete feedback unit or control head.

flow cone

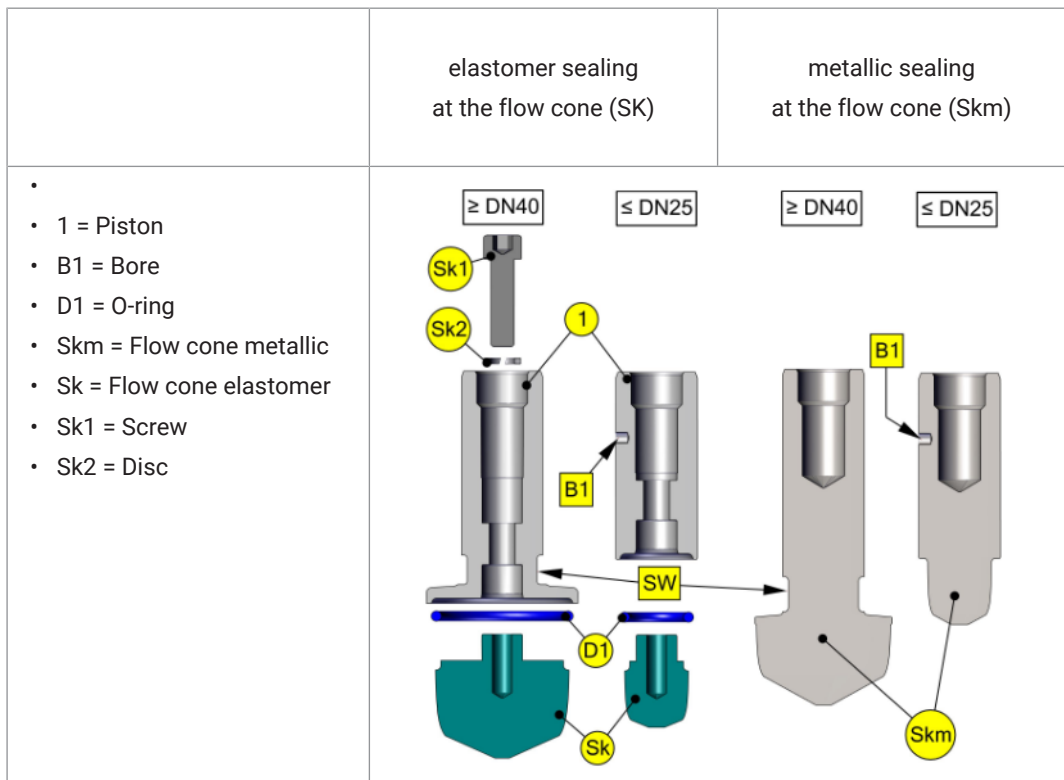

8.1.1 Removing wearing parts - Valve with manual actuator

Dismount the valve insert

- Unscrew the clamp coupling (VK).
- Dismount the valve insert (VE1) out of the housing (VG).
- Remove the housing bottom (Gb1) and interchangeable seat (Ws).
- Remove the O-rings (D6) and (D7).

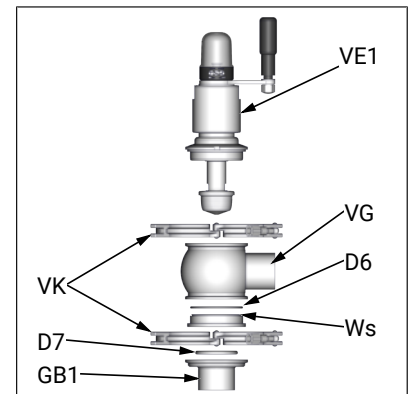

Figure 1

Replacement of seals



INFORMATION

Construction-conditioned, there are two variants for dismantle of the piston (1) or metallic sealing flow cone (Skm):

- Fig. 3: Dismounting via bore (B1) (\leq DN25).
- ⇒ So that the bore (B1) will be visible, first unscrew the insert (2).
- Fig. 4 Dismounting via spanner flat (SW1) (\geq DN40).

NOTICE!

The piston rod must be locked for the following steps:

- Hold the piston rod (9) with a punch (T31) at the bore (B2).
- For this purpose, the bore (B2) in the housing (2) and in the piston rod (9) must be adjusted congruently using the hand crank (19).
- Now push the punch (T31) into the hole (B2).

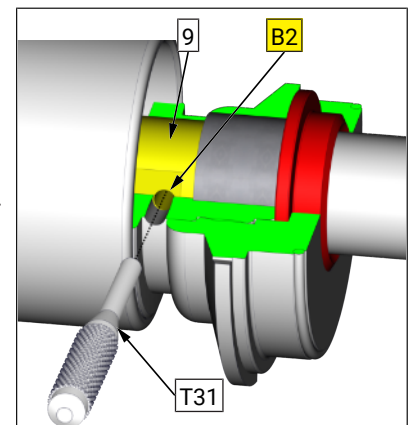

Figure 2

- So that the bore (B1) will be visible, first unscrew the insert (2) as shown in figure.
- Hold the piston rod (9) with a punch (T31) at the bore (B2).
- For this purpose, the bore (B2) in the housing (2) and in the piston rod (9) must be adjusted congruently using the hand crank (19).
- Unscrew the piston (1) respectively the flow cone (Skm) with a pin wrench (T10).

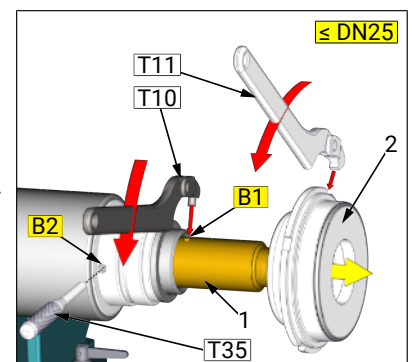

Figure 3

- Unscrew the piston (1) respectively the flow cone (Sk_m) with a spanner (T1) from spindle (11).
Hold on at the spanner flat (SW1).

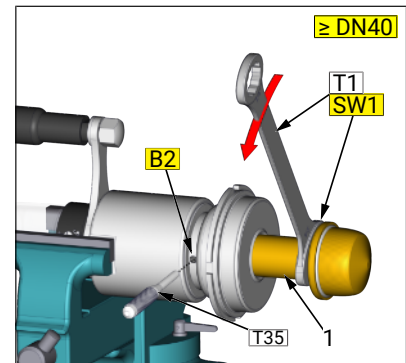

Figure 4

- Unscrew with a hook wrench (T11) the insert (2) from the lantern (14).

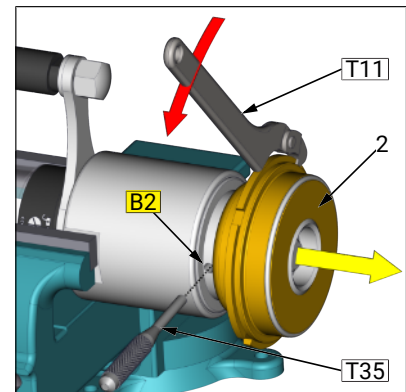

Figure 5

- The manual actuator (HA) do not need to be removed for a seal change.
- Remove O-ring (2) and seal (D3).

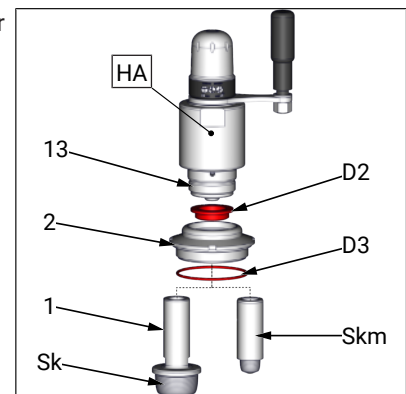

Figure 6

- Clamp the cone (Sk) in a soft jawed vice. Unscrew the screw (Sk1).
Remove piston (1) and O-ring (D1).

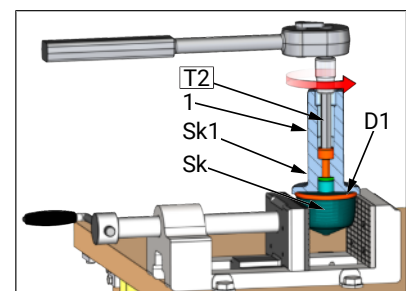

Figure 7



NOTICE

Bearing bush (3) do not need to be removed for a seal change. The positions are not included in the seal set. If they are worn, please order them with the seals (see wearing parts kit).

8.1.2 Removing wearing parts - Valve with piston actuator

Remove the valve insert (NC)

- Connect compressed air to air supply (LA2). The piston (1) retracts.
- Unscrew the clamp coupling (VK).
- Dismount the valve insert (VE2) out of the housing (VG).
Disconnect compressed air from air supply (LA2). The piston (1) returns to the basic position.

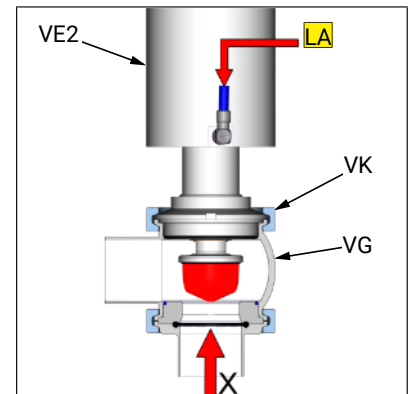

Figure 1

Remove the valve insert (NO) (DA)

- Unscrew the clamp coupling (VK).
- Dismount the valve insert (VE2) out of the housing (VG).

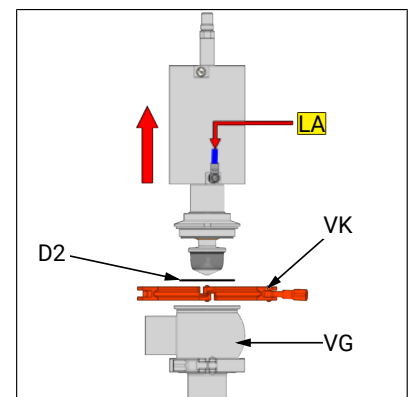

Figure 2

Replacement of seals

- Remove O-ring (D2).



INFORMATION

Construction-conditioned, there are two variants for dismantle of the piston (1) or metallic sealing flow cone (Skm):

- Fig. 3 Dismounting via bore (B1) (\leq DN25). So that the bore (B1) will be visible, first unscrew the insert (2) as shown in figure 3.
- Fig. 4 Dismounting via spanner flat (SW1) (\geq DN40).

- So that the bore (B1) will be visible, first unscrew the insert (2) as shown in figure.
- Unscrew the piston (1) respectively the flow cone (Skm) from the spindle (6) with a pin wrench (T10).
Hold on at the spanner flat (SW2).

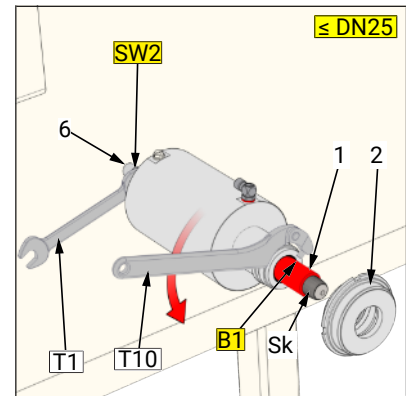

Figure 3

- Unscrew the piston (1) respectively the flow cone (Skm) with a spanner (T1) from spindle (6).
Hold on at the spanner flat (SW2).

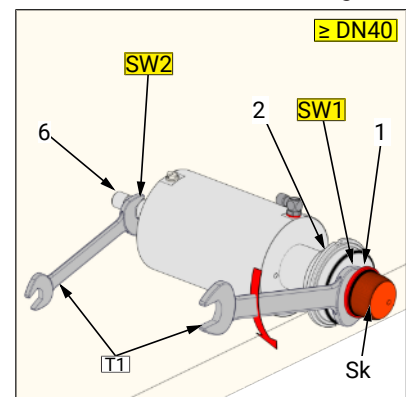

Figure 4

- Unscrew with a hook wrench (T11) the insert (2) from the lantern (4).
For this, holding on the lantern (4) with a pin wrench (T10).
- Remove seal (D3).

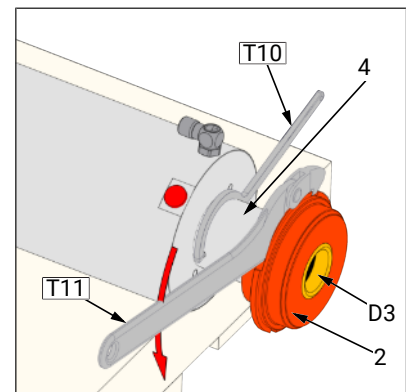

Figure 5

- Unscrew the lantern (4) with a pin wrench (T10) from actuator (PHA) and push it from piston rod (6).

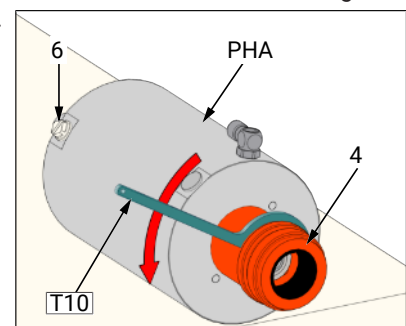

Figure 6

- Remove the distance (8), O-rings (D4) and (D5).

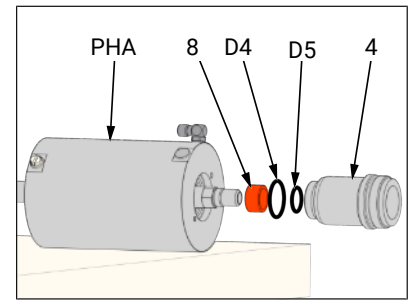

Figure 7



NOTICE

The distance (8) is fitted only with metric valves.

The bearing bushes (3) and (5) and the O-rings (D4) and (D5) do not need to be removed for a product-contacted seal change. The positions are not included in the seal set. If they are worn, please order them (see wearing parts kit).

- Unscrew the insert (7) from the actuator (PHA) with a pin type face spanner (T12).

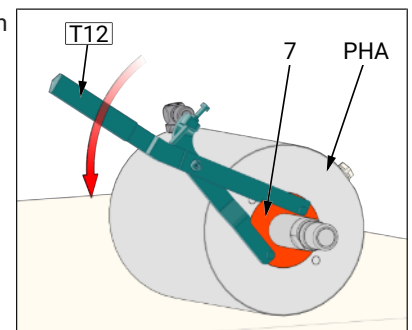

Figure 8

- Remove the O-rings (D4) and (D5).

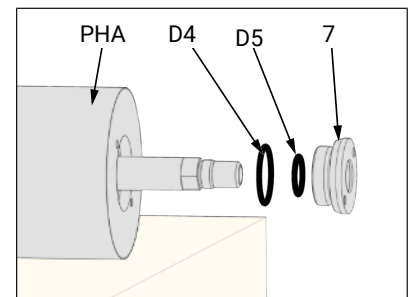

Figure 9

- Clamp the cone (Sk) in a soft jawed vice. Unscrew the screw (Sk1). Remove piston (1) and dismantle O-ring (D1).

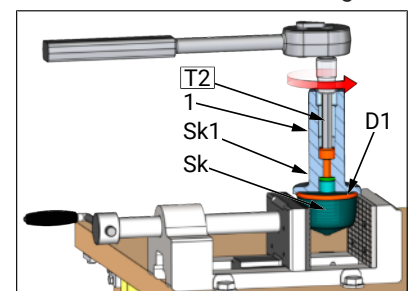

Figure 10

8.1.3 Removing wearing parts - Valve with diaphragm actuator

Remove the valve insert (NC)

- Connect compressed air to air supply (LA2). The piston (1) retracts.
- Unscrew the clamp coupling (VK).
- Dismount the valve insert (VE3) out of the housing (VG).
Disconnect compressed air from air supply (LA2). The piston (1) returns to the basic position.

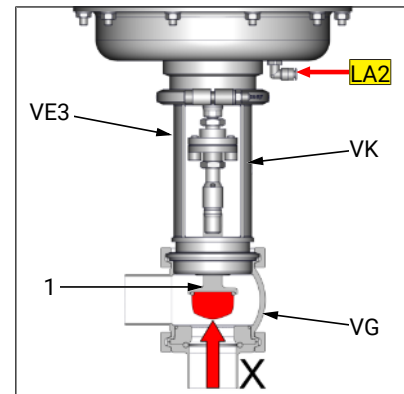

Figure 1

Remove the valve insert (NO) (DA)

- Unscrew the clamp coupling (VK).
- Dismount the valve insert (VE3) out of the housing (VG).

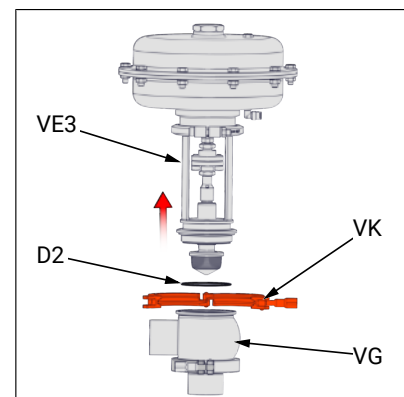

Figure 2

Replacement of seals

- Remove O-ring (D2).



INFORMATION

Construction-conditioned, there are two variants for dismantle of the piston (1) or metallic sealing flow cone (Skm):

- Fig. 3 Dismounting via bore (B1) (\leq DN25). So that the bore (B1) will be visible, first unscrew the insert (2) as shown in figure 3.
- Fig. 4 Dismounting via spanner flat (SW1) (\geq DN40).

- So that the bore (B1) will be visible, first unscrew the insert (2).
- Unscrew the piston (1) respectively the flow cone (Sk_m) from the spindle (6) with a pin wrench (T10).
Use a round rod (T31) to hold up against the spindle (6) via the bore (Ø5).

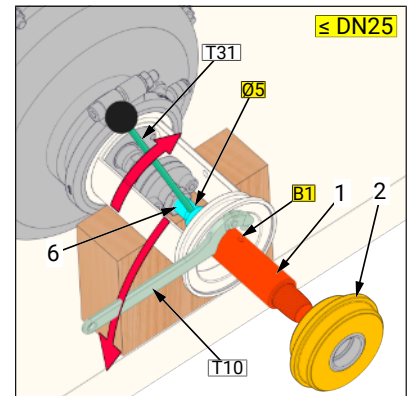

Figure 3

- Unscrew the piston (1) respectively the flow cone (Sk_m) with a spanner (T1) from spindle (6).
Use a round rod (T31) to hold up against the spindle (6) via the bore (B1).

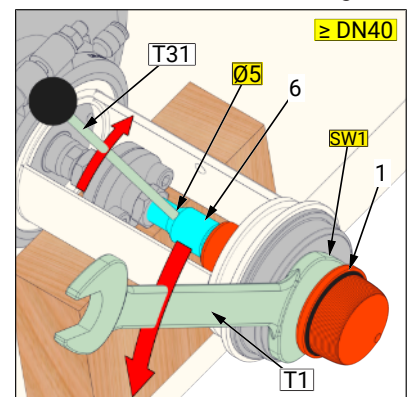

Figure 4

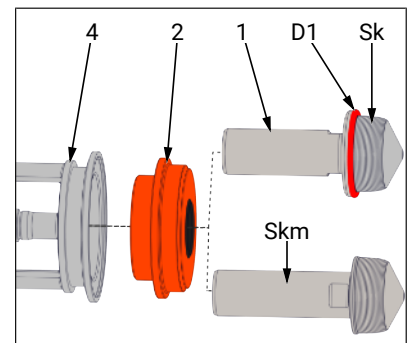

Figure 5

- Clamp the insert (2) in a soft jawed vice.
Unscrew the lantern insert (7) from the insert (2) with a pin type face spanner (T12).

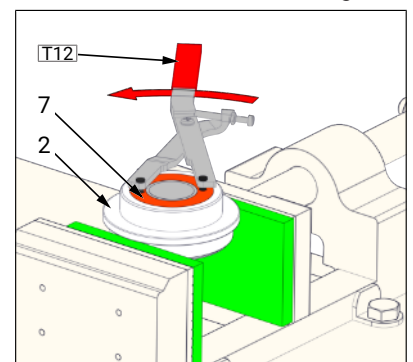

Figure 6

- Dismount seal (D3).

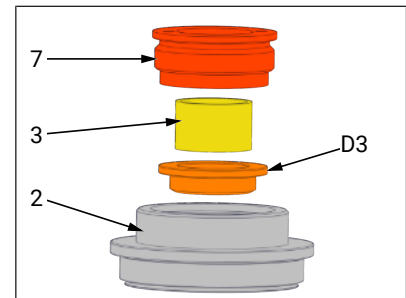

Figure 7



NOTICE

The bearing bush (3) do not need to be removed for a product-contacted seal change. The positions are not included in the seal set. If they are worn, please order them (see wearing parts kit).

- Clamp the cone (Sk) in a soft jawed vice. Unscrew the screw (Sk1). Remove piston (1) and dismantle O-ring (D1).

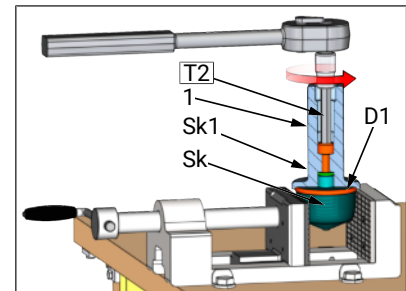

Figure 8

8.1.4 Removing Interchangeable seat

- Unscrew the clamp coupling (VK).
- Remove housing bottom (GB), interchangeable seat (WS), O-ring (D6) and (D7) from housing (VG).

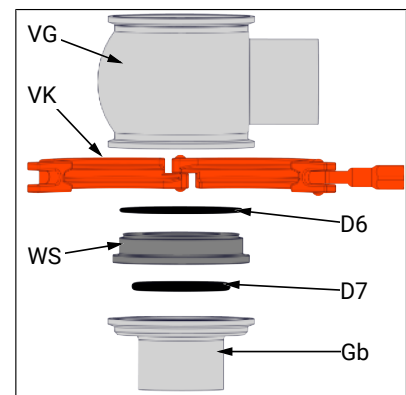

Figure 1

8.2 Assembly

- Assemble in reverse order.
- Before installation, thoroughly clean and slightly lubricate mounting areas and running surfaces.
- Check the function according to the specified performance data in the operating state.



NOTICE

Screw locking

- Assemble the thread connection (G1) with removable screw retention.
 - e. g. Loctite 243

Clamp coupling (VK)



NOTICE

During assembly, the following points must be observed!

Carefully fit in the complete valve insert into the casing. When fitting the valve insert and running surfaces onto the piston, do not damage.

➤ **Mounting clamp coupling**

- For mounting the clamp coupling, please note that it continuously fits form locking to the inclinations of the casing and the lantern/casing bottom.
- The centring of the retaining clamp during tightening can be accomplished with a slight beat (please use a soft-head hammer) on the extent of the retaining clamp.
- When tightening the clamp coupling, please pay attention to the turning moment and the gap size 'S' ($\leq 0,4\text{mm}$) between the components.
- Check valve functions by manually activating the 3/2-way solenoid valves after assembly!

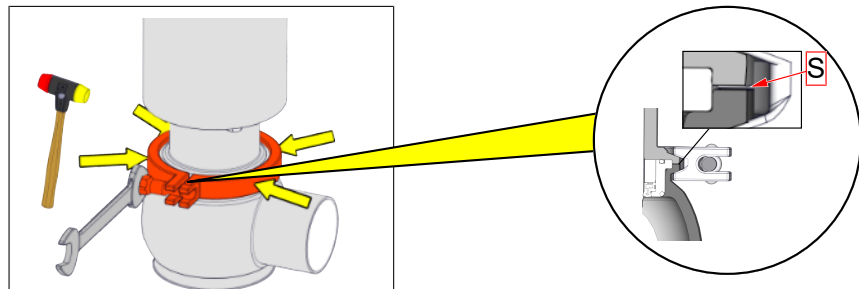

Torques

	DN	25	40	50	65	80	100
	Inch	1	1½	2	2½	3	4
Clamp coupling (Nm):		15	15	15	25	25	55

9 Mounting kit for positioner

9.1 Bürkert positioner Type 8692, 8694

Disassembly



NOTICE

Before reaching into the device or the equipment, please note the operating instructions and the safety instructions for the Bürkert Positioner.

(Operating instructions for Bürkert Type 8615500120 / Type 8615500130-000)



CAUTION

Risk of breakage

Breakage of the pneumatic connection pieces due to rotational impact!

- Before reaching into the device or the equipment, disconnect the compressed-air supply at the Positioner.
- Hold the electrical connection housing when unscrewing the housing jacket.

<ul style="list-style-type: none"> Hold the electrical connection housing (B2) in place. Unscrew the housing jacket (B1) in a counter-clockwise direction and remove them. Remove the seal (1.2). Remove electronics module (BSM). 	<ul style="list-style-type: none"> Pull off the puck (B5) upwards from the shift spindle (B7). Screw out the screws (B4) max. 6-7 turns, <u>not unscrewed</u>. <ul style="list-style-type: none"> - (when unscrew complete the sheet metal nut is destroyed and must be replaced.) 	<ul style="list-style-type: none"> Remove carefully the Positioner upwards. Unscrew the screws (B12) and remove the adapter (B9). Unscrew the spindle adapter (B8) with the stem (B7) from the actuator spindle.

Assembly

- Assemble in reverse order.
- Before installation, thoroughly clean and slightly lubricate mounting areas and running surfaces.
- Check the function according to the specified performance data in the operating state.

**CAUTION****Risk of breakage**

Breakage of the pneumatic connection pieces due to rotational impact!

- When inserting the housing jacket, do not hold the actuator but the electrical connection housing above.
- Check that the seal is correctly positioned on the housing jacket.
- Tighten the screws (B4) only lightly (maximum tightening torque: 0.5 Nm).

**CAUTION****Risk of breakage**

Be careful not damage the pins at the board!

- Attach electronics module carefully and press down evenly until the holders snap into place.

Art.-No.: 5200 104 561-000 (B2+B4 nickelized)

Art.-No.: 5200 104 561-100 (B2+B4 V2A)

Electro-pneumactical Positioner (the Positioner is not include in the mounting kit)

- B1 = Housing body
- B2 = Electrical connection
- B3 = Housing actuator
- B4 = Fastening screw
- B5 = Puck
- B6 = Seal
- B7 = Spindle
- B8 = Spindle adapter M4-M10
- B9 = Adapter
- B10 = O-ring
- B11 = Disc
- N12 = Screw DIN933

BS1 = Circular plug-in connector 24V DC
(electrical connection)

BEM = Electronics Module

B.LA1 = Additional air port

B.LA2 = Additional Exhaust

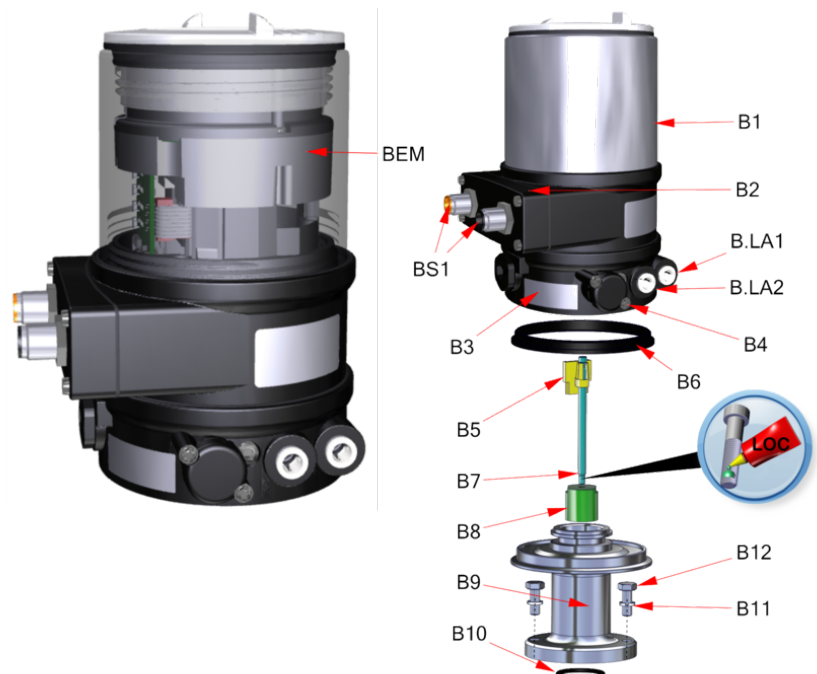

10 Drawings and dimensions

10.1 Drawings

Valve structure

	Manual operation with crank handle	Pneumatic operation with piston actuator	Pneumatic operation with diaphragm actuator
<p>A = Positioner DIGIPOS B = Positioner Bürkert Type 869x C = Positioner Samson</p> <p>VE1 = Valve insert manual operation VE2 = Valve insert with pneum. piston actuator VE3 = Valve insert with diaphragm actuator</p>			
<p><u>Housing design</u></p> <p>VG1) = Angle - form (S-S) VG2) = T-Form (SS-S) VG3) = Inclined - form (S-S)</p>			

Valve inserts

- 1 = Piston
- 2 = Insert
- 3 = Plain bearing
- 4 = Lantern
- 5 = Bearing bush
- 6 = Spindle
- 7 = Insert lantern
- 8 = Valve lift stop

(not applicable by Inch-version)

- 9 = Piston rod
- 10 = Set screw
- 11 = Spindle
- 12 = Bearing bush
- 13 = Housing
- 14 = Housing body
- 15 = Guide nut
- 16 = Adapter
- 17 = Cap
- 18 = Hood
- 19 = Crank handle

Manual operation
with crank handle

Pneumatic operation
with piston actuator

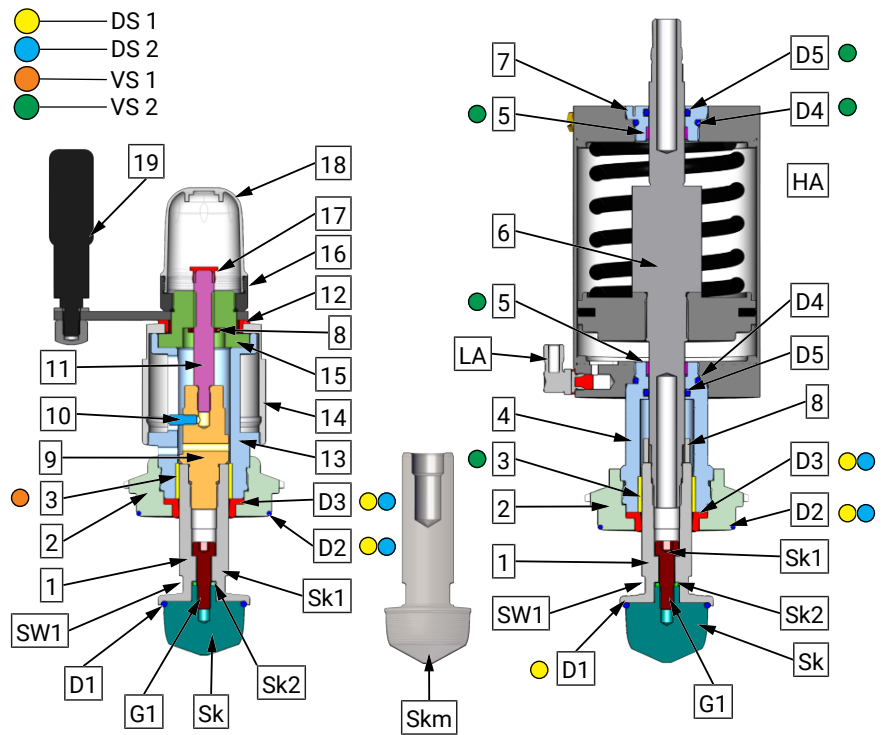

seals

- D1 = O-ring
- D2 = O-ring
- D3 = Shaft seal
- D4 = O-ring
- D5 = O-ring
- D6 = O-ring
- D7 = O-ring

- Gb1 = Housing bottom straight
- Gb2 = Housing bottom inclined
- Skm = Flow cone metallic
- Sk = Flow cone elastomer
- Sk1 = Screw
- Sk2 = Disc
- VG1 = Housing angle form
- VG2 = Housing T - form
- VG3 = Housing Inclined - form
- VK = Clamp coupling
- Ws = Interchangeable seat
- G1 = Secure with threaded connection "removable" (e.g. Loctite 243).
- SW = Wrench size
- PHA = pneum. Actuator

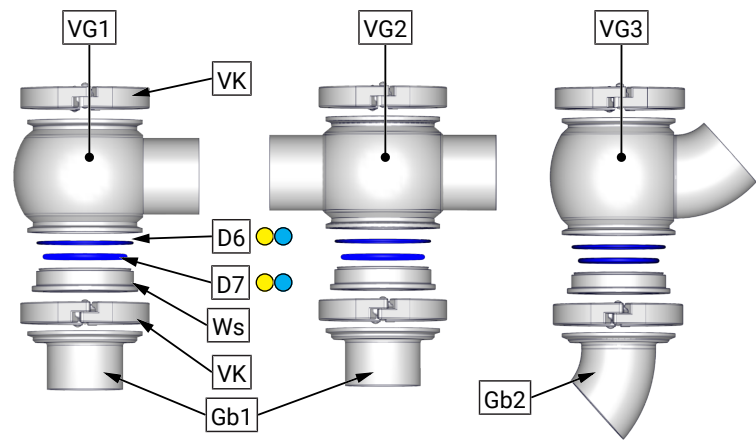

SW = Wrench size

Wrench size	DN = Nominal diameter OD = Outside diameter						
	DN 25 OD 1 "	DN 40 OD 1½ "	DN 50 OD 2 "	DN 65 OD 2½ "	DN 80 OD 3 "	DN 100 OD 4 "	DN 125 OD 5 "
SW1	-	24					
SW2	17						
SW3	11						
SW4	17						
SW5	22						

10.2 Dimensions

Valve kind: Kind of actuation: Actuator:	Manual operation with crank handle (manual)	Pneumatic operation with piston actuator (H104 / H129 / H267 / H230)	Pneumatic operation with diaphragm actuator (M02 / M2 / M4 / M10)

Dimensions											
Nominal width	D	A	B	C	E	Actuator	F	G*	H**	Y	M
DN 20	Ø 23 x 1,5	65	65	-	-	H104	Ø 104	446	-	-	~520
DN 25	Ø 29 x 1,5	75	75	82	57	manual	-	~224	-	88	-
OD 1	Ø25.4x1.25				54	H104	Ø 104	459	-	-	~530
						H129	Ø 129	459	-	-	~530
						M02	Ø 165	437	287	-	~540
						M2	Ø 270	487	334	-	~600
DN 40	Ø 41 x 1,5	85	85	129	69	manual	-	~230	-	88	-
OD 1"	Ø38,1 x 1,65				66.1	H104	Ø 104	466	-	-	~540
						H129	Ø 129	466	-	-	~540
						M02	Ø 165	443	293	-	~540
						M2	Ø 270	493	340	-	~650
DN 50	Ø 53 x 1,5	85	85	150	81	manual	-	~236	-	88	-
OD 2	Ø50,8 x 1,65				79	H104	Ø 104	472	-	-	~570
						H129	Ø 129	472	-	-	~570
						H167	Ø 167	472	-	-	~570
						M2	Ø 270	505	355	-	~510
						M4	Ø 270	494	341	-	~650
DN 65	Ø 70 x 2,0	105	105	188	97	manual	-	~244	-	88	-
OD 2"	Ø63,5 x 1,65				91.5	H129	Ø 129	480	-	-	~600
						H167	Ø 167	480	-	-	~600
						H190	Ø 190	480	-	-	~600
						H230	Ø 230	480	-	-	~600
						M2	Ø 270	511	358	-	~660
						M4	Ø 270	511	358	-	~660
						M10	Ø 400	598	445	-	~720
DN 80	Ø 85 x 2,0	115	115	222	112	manual	-	~252	-	88	-
OD 3	Ø76.2x1.65				104	H129	Ø 129	487	-	-	~620
						H167	Ø 167	487	-	-	~620
						H190	Ø 190	487	-	-	~620
						H230	Ø 230	487	-	-	~620
						M2	Ø 270	519	366	-	~670
						M4	Ø 270	519	366	-	~670
						M10	Ø 400	606	453	-	~740
DN 100	Ø 104 x 2,0	130	130	250	131	manual	-	~261	-	88	-
OD 4	Ø101,6 x 2,0				129	H129	Ø 129	497	-	-	~650
						H167	Ø 167	497	-	-	~650
						H190	Ø 190	497	-	-	~650
						H230	Ø 230	497	-	-	~650
						M4	Ø 270	540	387	-	~690
						M10	Ø 400	619	466	-	~770
DN 125	Ø 129 x 2,0	160	160	-	-	manual	-	~274	-	88	-
						H190	Ø 190	510	-	-	~690
						H230	Ø 230	510	-	-	~690
						M4	Ø 270	553	400	-	~700
						M10	Ø 400	632	479	-	~880
*	Dimension G: actuator with top-mounted positioner										
**	Dimension H: positioner mounted on NAMUR interface										

11 Wearing parts

11.1 Overview - Seal and wearing parts kits

Wear parts kit - in product contact	Material:	Designation
DS 1	a	Elastomer / EPDM
	b	Elastomer / HNBR
	c	Elastomer / VITON
DS 2	a	metallic / EPDM
	b	metallic / HNBR
	c	metallic / FKM

Wear parts kit - Actuator	Material:	Designation
VS 1		Wearing parts set for manual operation valves (without positions from the wearing part set - in product contact)
VS 2		Wearing parts set for pneumatic operation valves with piston actuator (without positions from the wearing part set - in product contact)
VS 3		Wearing parts set for pneumatic operation valves with diaphragm actuator (without positions from the wearing part set - in product contact)

Pos.	Designation	DS 1	DS 2	VS 1	VS 2	VS 3
		a / b / c	a / b / c			
D1	O-Ring (EPDM / HNBR / FKM)	x				
D2	O-Ring (EPDM / HNBR / FKM)	x	x			
D3	Seal (EPDM / HNBR / FKM)	x	x			
D4	O-ring (NBR)				x	
D5	O-ring (HNBR)				x	
D6	O-Ring (EPDM / HNBR / FKM)	x	x			
D7	O-Ring (EPDM / HNBR / FKM)	x	x			
D8	O-ring					x
D9	O-ring					x
D10	Scraper ring (NBR)					x
D11	O-ring					x
D12	O-ring					x
3	Plain bearing (XSM)			x	x	
5	Plain bearing (XSM)				x	
13	Scraper ring (NBR)			x		
25	Plain bearing (XSM)					x

Wearing part set DS1 (elastomeric sealing)

DN OD	K _{vs} Value	Seat-Ø	Wear parts kit DS 1a EPDM	Wear parts kit DS 1b HNBR	Wear parts kit DS 1c FKM
25	0.4	Ø 6	5119 104 000-K000	5119 104 000-O000	5119 104 000-S000
	1.0				
	1.6	Ø 12	5119 120 000-K000	5119 120 000-O000	5119 120 000-S000
	2.5				
	4.0				
1"	7.0	Ø 22	5119 170 000-K000	5119 170 000-O000	5119 170 000-S000
	10.0				
	0.4	Ø 6	5129 104 000-K000	5129 104 000-O000	5129 104 000-S000
	1.0				
	1.6	Ø 12	5129 120 000-K000	5129 120 000-O000	5129 120 000-S000
1½"	2.5				
	4.0				
	7.0	Ø 22	5129 170 000-K000	5129 170 000-O000	5129 170 000-S000
40	10.0				
	4.0	Ø 12	5119 240 000-K000	5119 240 000-O000	5119 240 000-S000
	7.0	Ø 22	5119 270 000-K000	5119 270 000-O000	5119 270 000-S000
	10				
1½"	18	Ø 31	5119 291 000-K000	5119 291 000-O000	5119 291 000-S000
	4.0	Ø 12	5129 240 000-K000	5129 240 000-O000	5129 240 000-S000
	7.0	Ø 22	5129 270 000-K000	5129 270 000-O000	5129 270 000-S000
	10				
50	18	Ø 31	5129 291 000-K000	5129 291 000-O000	5129 291 000-S000
	10				
	18	Ø 31	5119 351 000-K000	5119 351 000-O000	5119 351 000-S000
	26	Ø 46	5119 333 000-K000	5119 333 000-O000	5119 333 000-S000
2"	40				
	10	Ø 22	5129 351 000-K000	5129 351 000-O000	5129 351 000-S000
	18	Ø 31	5129 391 000-K000	5129 391 000-O000	5129 391 000-S000
	26	Ø 46	5129 333 000-K000	5129 333 000-O000	5129 333 000-S000
65	40				
	18	Ø 31	5119 491 000-K000	5119 491 000-O000	5119 491 000-S000
	26	Ø 46	5119 433 000-K000	5119 433 000-O000	5119 433 000-S000
	40				
	52	Ø 60	5119 473 000-K000	5119 473 000-O000	5119 473 000-S000
2½"	68				
	18	Ø 31	5129 491 000-K000	5129 491 000-O000	5129 491 000-S000
	26	Ø 46	5129 433 000-K000	5129 433 000-O000	5129 433 000-S000
	40				
2½"	52	Ø 60	5129 473 000-K000	5129 473 000-O000	5129 473 000-S000
	68				
	52	Ø 60	5129 473 000-K000	5129 473 000-O000	5129 473 000-S000

80	26	∅ 46	5119 533 000-K000	5119 533 000-O000	5119 533 000-S000
	40				
	68	∅ 60	5119 593 000-K000	5119 593 000-O000	5119 593 000-S000
	85	∅ 72	5119 554 000-K000	5119 554 000-O000	5119 554 000-S000
3"	100	∅ 81	5119 535 000-K000	5119 535 000-O000	5119 535 000-S000
	26	∅ 46	5129 533 000-K000	5129 533 000-O000	5129 533 000-S000
	40				
	68	∅ 60	5129 593 000-K000	5129 593 000-O000	5129 593 000-S000
100	85	∅ 72	5129 554 000-K000	5129 554 000-O000	5129 554 000-S000
	100				
100	100	∅ 81	5119 635 000-K000	5119 635 000-O000	5119 635 000-S000
	120	∅ 95	5119 617 000-K000	5119 617 000-O000	5119 617 000-S000
4"	100	∅ 72	5129 635 000-K000	5129 635 000-O000	5129 635 000-S000
	120	∅ 95	5129 617 000-K000	5129 617 000-O000	5129 617 000-S000
125	100	∅ 81	5119 735 000-K000	5119 735 000-O000	5119 735 000-S000
	160	∅ 125	5119 755 000-K000	5119 755 000-O000	5119 755 000-S000
5"	100	∅ 72	5129 735 000-K000	5129 735 000-O000	5129 735 000-S000
	160	∅ 125	5129 755 000-K000	5129 755 000-O000	5129 755 000-S000

Wearing part set DS2 (metallic sealing)

DN OD	K _{vs} Value	Seat-Ø	Wear parts kit DS 2a EPDM	Wear parts kit DS 2b HNBR	Wear parts kit DS 2c FKM
25	0.4	Ø 6	5119 104 000-M000	5119 104 000-Q000	5119 104 000-U000
	1.0				
	1.6	Ø 12	5119 120 000-M000	5119 120 000-Q000	5119 120 000-U000
	2.5				
	4.0				
7.0	Ø 22	5119 170 000-M000	5119 170 000-Q000	5119 170 000-U000	
10.0					
1"	0.4	Ø 6	5129 104 000-M000	5129 104 000-Q000	5129 104 000-U000
	1.0				
	1.6	Ø 12	5129 120 000-M000	5129 120 000-Q000	5129 120 000-U000
	2.5				
	4.0				
7.0	Ø 22	5129 170 000-M000	5129 170 000-Q000	5129 170 000-U000	
10.0					
40	4.0	Ø 12	5119 240 000-M000	5119 240 000-Q000	5119 240 000-U000
	7.0				
	10	Ø 22	5119 270 000-M000	5119 270 000-Q000	5119 270 000-U000
18	Ø 31				
1½"	4.0	Ø 12	5129 240 000-M000	5129 240 000-Q000	5129 240 000-U000
	7.0				
	10	Ø 22	5129 270 000-M000	5129 270 000-Q000	5129 270 000-U000
18	Ø 31				
50	10	Ø 22	5119 351 000-M000	5119 351 000-Q000	5119 351 000-U000
	18				
	26	Ø 46	5119 333 000-M000	5119 333 000-Q000	5119 333 000-U000
	40				
2"	10	Ø 22	5129 351 000-M000	5129 351 000-Q000	5129 351 000-U000
	18				
	26	Ø 46	5129 333 000-M000	5129 333 000-Q000	5129 333 000-U000
	40				
65	18	Ø 31	5119 491 000-M000	5119 491 000-Q000	5119 491 000-U000
	26				
	40	Ø 60	5119 473 000-M000	5119 473 000-Q000	5119 473 000-U000
	52				
68					
2½"	18	Ø 31	5129 491 000-M000	5129 491 000-Q000	5129 491 000-U000
	26				
	40	Ø 60	5129 473 000-M000	5129 473 000-Q000	5129 473 000-U000
	52				
68					

80	26	∅ 46	5119 533 000-M000	5119 533 000-Q000	5119 533 000-U000
	40				
	68	∅ 60	5119 593 000-M000	5119 593 000-Q000	5119 593 000-U000
	85	∅ 72	5119 554 000-M000	5119 554 000-Q000	5119 554 000-U000
3"	100	∅ 81	5119 535 000-M000	5119 535 000-Q000	5119 535 000-U000
	26	∅ 46	5129 533 000-M000	5129 533 000-Q000	5129 533 000-U000
	40				
	68	∅ 60	5129 593 000-M000	5129 593 000-Q000	5129 593 000-U000
100	85	∅ 72	5129 554 000-M000	5129 554 000-Q000	5129 554 000-U000
	100				
100	100	∅ 81	5119 635 000-M000	5119 635 000-Q000	5119 635 000-U000
	120	∅ 95	5119 617 000-M000	5119 617 000-Q000	5119 617 000-U000
4"	100	∅ 72	5129 635 000-M000	5129 635 000-Q000	5129 635 000-U000
	120	∅ 95	5129 617 000-M000	5129 617 000-Q000	5129 617 000-U000
125	100	∅ 81	5119 735 000-M000	5119 735 000-Q000	5119 735 000-U000
	160	∅ 125	5119 755 000-M000	5119 755 000-Q000	5119 755 000-U000
5"	100	∅ 72	5129 735 000-M000	5129 735 000-Q000	5129 735 000-U000
	160	∅ 125	5129 755 000-M000	5129 755 000-Q000	5129 755 000-U000

Wearing part set - Actuator

Kind of actuation		Wear parts kit Actuator 1	Wear parts kit Actuator 2	Wear parts kit Actuator 3
manual actuator	-	5139 000 001-K000		
Linear actuator	∅104		5139 000 001-K100	
	∅129		5139 000 001-K200	
	∅167		5139 000 001-K300	
	∅230		5139 000 001-K400	
Diaphragm actuator	M02			5200 165 500-G000
	M2			5200 270 500-G000
	M4			5200 270 500-G000
	M10			5200 400 500-G000

12 Classification

12.1 Structure of Order Number

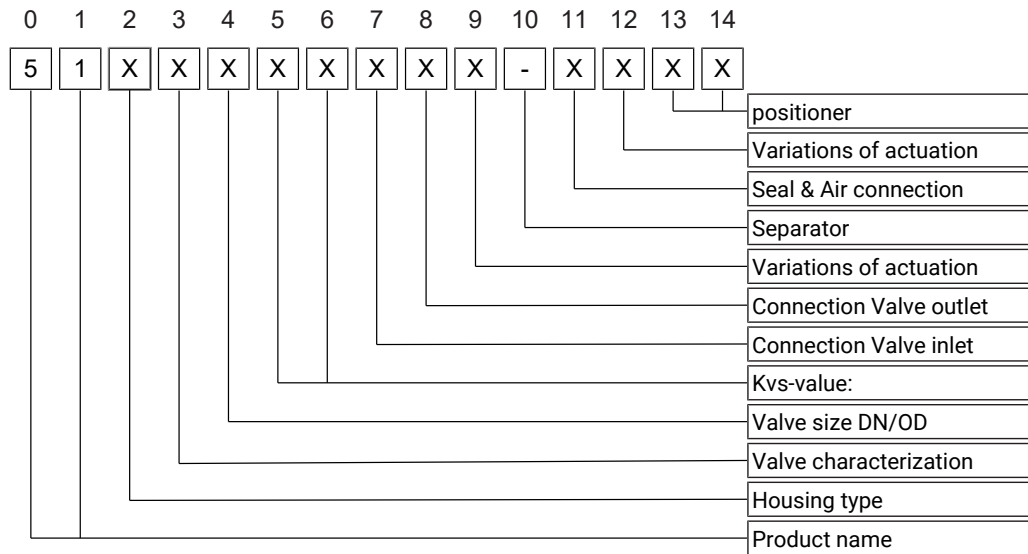

Product name

51xx xxx xxx-xxxx	Pos. 0	Pos. 1
Product name: Control valve	5	1

Housing type

51Xx xxx xxx-xxxx	Pos. 2
Angle valve	1
T-valve	2
- Inclined	3

Valve characterization

51xX xxx xxx-xxxx			Pos. 3
DIN/Inch	Curve	Pneum. actuator	
DIN	equal percentage	NC	0
DIN	equal percentage	NO (FÖ-LS)	1
DIN	linear	NC	2
DIN	linear	NO (FÖ-LS)	3
Inch	equal percentage	NC	4
Inch	equal percentage	NO (FÖ-LS)	5
Inch	linear	NC	6
Inch	linear	NO (FÖ-LS)	7
DIN	equal percentage	DA	A
DIN	linear	DA	B
Inch	equal percentage	DA	C
Inch	linear	DA	D

Valve size

51xx X xx xxx-xxxx		Pos. 4
DN	OD	
DN 10	OD 1/2"	0
DN 25	OD 1"	1
DN 40	OD 1 1/2"	2
DN 50	OD 2 "	3
DN 65	OD 2 1/2"	4
DN 80	OD 3 "	5
DN 100	OD 4 "	6
DN 125	OD 5"	7
DN 150	OD 6 "	8
DN 200	OD 8 "	9

Kvs-value:

51xx x X X xxx-xxxx					
K _{vs} (m ³ /h)	Pos. 5	Pos. 6	K _{vs} (m ³ /h)	Pos. 5	Pos. 6
0.4	0	4	40	5	3
1.0	1	0	52	7	3
1.6	2	0	68	9	3
2.5	3	0	85	5	4
4.0	4	0	100	3	5
7.0	7	0	120	1	7
10	5	1	160	5	5
18	9	1	250	8	5
26	3	3			

Connection Valve inlet

51xx xxx X x-xxxx	Pos. 7
Connection	
Welding end	0
K/M	1
Clamp	2
Thread	3
KK-Small flange	4
Flange DIN 11853-2	5
Flange DIN 11864-2	6

Connection Valve outlet

51xx xxx x X x-xxxx	Pos. 8
Connection	
Welding end	0
K/M	1
Clamp	2
Thread	3
KK-Small flange	4
Flange DIN 11853-2	5
Flange DIN 11864-2	6

Variations of actuation

51xx xxx xx-X-xXxx					
Actuator KIESELMANN	Pos. 9	Pos. 12	Actuator GUTH	Pos. 9	Pos. 12
manual	1	0	Diaphragm actuator M02	2	0
Piston actuator Ø104	1	1	Diaphragm actuator M1	2	1
Piston actuator Ø129	1	2	Diaphragm actuator M2	2	2
Piston actuator Ø167	1	3	Diaphragm actuator M3	2	3
Piston actuator Ø167/2	1	4	Diaphragm actuator M4	2	4
Diaphragm actuator Ø150	1	5	Diaphragm actuator M9	2	5
Diaphragm actuator Ø200	1	6	Diaphragm actuator M10	2	6
Diaphragm actuator Ø285	1	7			

Separator

51xx xxx xxx-xxxx	Pos. 10
KIESELMANN Valve	-

Seal and Air connection

51xx xxx xxx-Xxxx		Pos. 11
Sealing material	Air connections	
EPDM	nickelized	K
EPDM	stainless steel	L
metallic EPDM	nickelized	M
metallic EPDM	stainless steel	N
HNBR	nickelized	O
HNBR	stainless steel	P
metallic HNBR	nickelized	Q
metallic HNBR	stainless steel	R
Viton	nickelized	S
Viton	stainless steel	T
metallic FKM	nickelized	U
metallic FKM	stainless steel	V

Kind of Positioner

51x xx xxx-xxXX	Pos. 13	Pos. 14
positioner		
Bürkert 8692	0	0
Bürkert 8792	0	1
GUTH DigiPos	0	2

13 Appendix

13.1 Declaration of incorporation



Declaration of incorporation

Translation of the original

Manufacturer / authorised representative:

KIESELMANN GmbH
Paul-Kieselmann-Str. 4-10
75438 Knittlingen
Germany

Authorised representative:
(for compiling technical documents)

Achim Kauselmann
Paul-Kieselmann-Str. 4-10
75438 Knittlingen
Germany

<u>Product name</u>	<u>Function</u>
pneum. Lift actuators	Stroke movement
pneum. Rotary actuators	Rotary movement
Ball valves	Media cutoff
Butterfly valves	Media cutoff
Single seat valves	Media cutoff
Flow control valves	Control of liquefied media
Throttle valve	Control of liquefied media
Overflow valve	Definition of fluid pressure
Double seat valve	Media separation
Bellow valves	Sampling of liquids
Sampling valves	Sampling of liquids
Two way valves	Media cutoff
Tankdome fitting	Prevention of overpressure and vacuum, Tank cleaning
Safety valve	Prevention of overpressure

The manufacturer hereby states that the above product is considered as an incomplete machine in the sense defined in the Directive 2006/42/EC on Machinery. The above product is exclusively intended to be installed into a machine or an incomplete machine. The said product does not yet conform to all the relevant requirements defined in the Directive on Machinery referred to above for this reason.

The specific technical documents listed in Appendix VII, Part B, have been prepared. The Authorized Agent empowered to compile technical documents may submit the relevant documents if such a request has been properly justified.

Commissioning of an incomplete machine must not only be carried out if it has been determined that the respective machine into which the incomplete machine is to be installed conforms to the regulations set out in the Directive on Machinery referred to above.

The above product conforms to the requirements of the directives and harmonized standards specified below:

- Directive 2014/68/EU
- DIN EN ISO 12100 Safety of machinery

Knittlingen, 21.07.2017

i.V. Uwe Heisswulf
Head of Development